



LVI LITTER PROCESSOR

Deluxe B Series

Deluxe B Series II

#LTMAN005

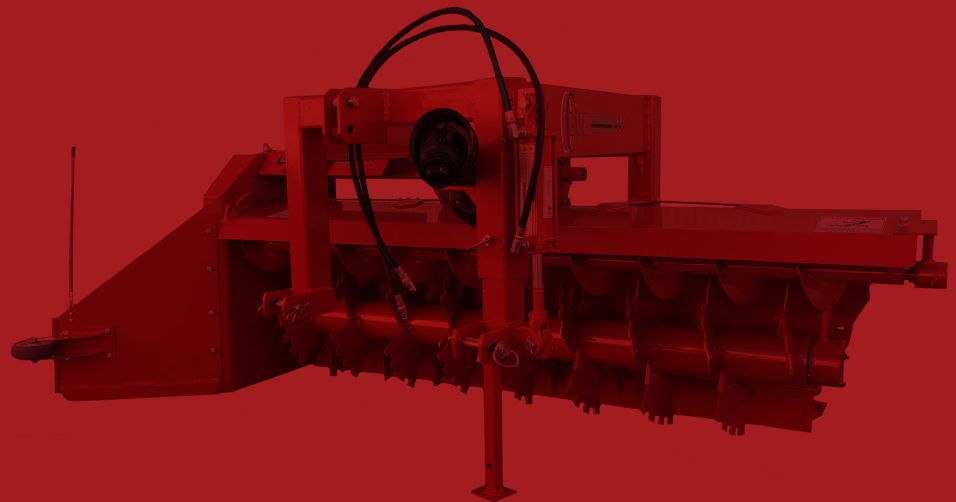

USER & PARTS MANUAL

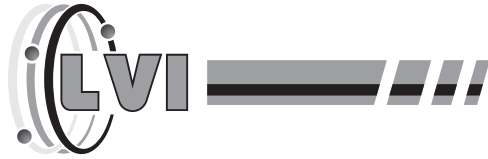

INDEX

Introduction	Pg. 3
Safety Decals	Pg. 4
Safety Message.....	Pg. 5
Operating Safety.....	Pg. 6
Maintenance Safety	Pg. 6
Hydraulic Safety	Pg. 7
Pre-operation Checklist.....	Pg. 8
Equipment Matching	Pg. 9
PTO Shaft Information	Pg. 9
Operation	Pg. 10
Gearbox Lubrication	Pg. 12
Shear Bolt & Drive Line	Pg. 13
Chain Case	Pg. 14
Bearings.....	Pg. 15
Chain Case	Pg. 14
Maintenance Schedule.....	Pg. 16
Warranty Forms	Pg. 68

Thank you for the Purchase & Support of your LVI Dairy Bedded Pack Composter!

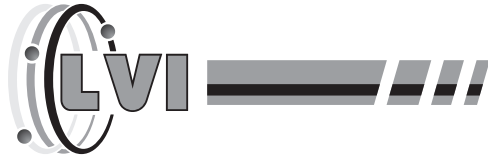

INTRODUCTION

Congratulations on your choice of a LVI LITTER PROCESSOR to complement your operation. This equipment has been designed and manufactured to meet the needs of the discriminating buyer for efficient processing of poultry litter. Safe, efficient and trouble free operation of your processor requires that you and anyone else who will be operating or maintaining the machine, read and understand the safety, operation, maintenance, and trouble-shooting information contained within the Operator's Manual.

This manual covers the Deluxe series manufactured by Binkley & Hurst, LP.

Keep this manual readily available for reference and be sure to pass it on to new operators or owners. Contact Binkley & Hurst, LP if you need assistance or information for a complete listing of parts and accessories.

OPERATOR ORIENTATION - The directions left, right, front and rear as mentioned throughout the manual are as seen from the tractor driver's seat, facing forward.

CUSTOMER REFERENCE INFORMATION

LVI Model Number: Deluxe: _____

LVI Serial Number: _____

Date Purchased: _____

Dealer Name: _____

Dealer Tel #: _____

BINKLEY & HURST, LP

Toll-free: 888.414.7518

LVI LITTER PROCESSOR PAGE: www.lvimfg.com

LVI DEALER LIST: www.lvimfg.com/dealer list

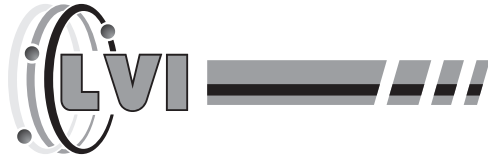

SAFETY DECALS

The safety decals have been placed on the machine at the time of manufacture. It is important that all the decals are kept clean and legible at all times. If any decals have become illegible or have been removed, replacements are available from Binkley & Hurst, LP.

Toll-free: 888.414.7518

These Safety Decals Are on your Deluxe processor.



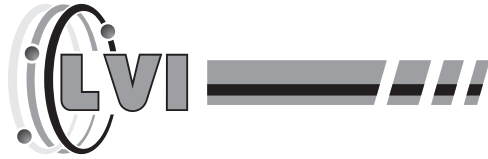

DANGER

You are responsible for the SAFE operation and maintenance of your LVI LITTER PROCESSOR. You must ensure that you, and anyone else who will be operating, maintaining, servicing or working around the processor be familiar with the operating and maintenance procedures and related safety information contained in this manual. This manual will take you step-by-step through the operation procedures and alerts you to all good safety practices that should be adhered to while operating the litter processor.

Remember, YOU are the key to safety. Good safety practices not only protect you, but also the people around you. Make these practices a working part of your safety program. Be certain that EVERYONE operating this equipment is familiar with the recommended operating and maintenance procedures and follows all the safety precautions. Most accidents can be prevented. Do not risk injury or death by ignoring good safety practices.

- Litter Processor owners must give operating instructions to their employees before allowing them to operate the machine and ensure that all operators have read and understood the safety and operating procedures.
- The most important safety device on the equipment is a SAFE operator. It is the operator's responsibility to read and understand ALL safety and operating instructions in the manual and follow them.
- A person who has not read and understood all operating and safety instructions is not qualified to operate this machine. An untrained operator exposes himself and bystanders to possible or serious injury or death.
- Do not modify the equipment in any way. Unauthorized modifications may impair the function and/or safety and could affect the life and warranty of the equipment.
- Think SAFETY! Work SAFELY!

Do not allow riders on machinery. Place all controls in neutral, stop the engine, set park brake, remove ignition key and wait for all moving parts to come to a complete stop before servicing, repairing or unplugging machinery.

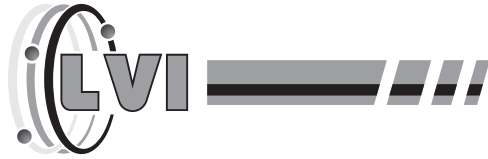

OPERATING SAFETY

1. Read and understand the Operator's Manual and all safety decals before using the equipment.
2. Clean reflectors, slow moving vehicle signs and lights before transporting.
3. Relieve pressure from hydraulic circuit before servicing or disconnecting from tractor.
4. Place all controls in neutral, stop the engine, set park brake, remove ignition key and wait for all moving parts to come to a complete stop before servicing or repairing.
5. Install and secure guards before starting.
6. Keep hands, feet, hair and clothing away from all moving and/or rotating parts.
7. Do not operate when guards are missing or broken.
8. Clear the area of all bystanders, especially children, before starting.
9. Do not allow children to play on or around the machine.
10. Do not allow riders on the LITTER PROCESSOR or tractor.
11. Be sure the PTO drive line guard telescopes and rotates freely on the shaft before installation.
12. Use hazard flashers on tractor when transporting on roads, and follow all local laws.
13. Review safety instructions annually.

MAINTENANCE SAFETY

1. Follow ALL the operating, maintenance, and safety information in this manual.
2. Place all controls in neutral, stop the engine, set park brake, remove ignition key and wait for all moving parts to come to a complete stop before servicing, adjusting, repairing or unplugging.
3. Relieve pressure from hydraulic circuit before servicing or disconnecting from tractor.
4. Support the machine with blocks or safety stands when working under it.

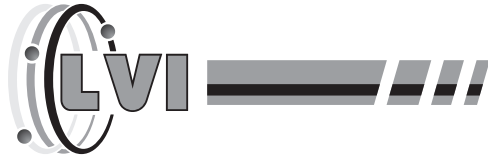

5. Follow good shop practices:
 - Keep service area clean and dry.
 - Be sure electrical outlets and tools are properly grounded.
 - Use adequate lighting for the job at hand
6. Use only tools, jacks and hoists of sufficient capacity for the job.
7. Make sure all guards and shields are in place and properly secured when maintenance work is completed.
8. Before applying pressure to the hydraulic system, make sure all lines, fittings and couplers are tight and in good condition.
9. Keep hands, feet, hair and clothing away from all moving and/or rotating parts.
10. Clear the area of all bystanders, especially children, when operating, repairing, or making adjustments to the machine.

STORAGE SAFETY

1. Store the unit in an area away from human activity.
2. Do not permit children to play on or around the stored machine.
3. Store the unit in a dry, level area.
4. Do not lay hydraulic hoses on the ground and keep the fittings free of dirt.
5. Make sure the implement jack is properly fastened to the unit.

HYDRAULIC SAFETY

1. Make sure that all components in the hydraulic system are kept in good condition and are clean.
2. Relieve pressure before working on the hydraulic system.
3. Replace any rusted, worn, cut, abraded, flattened or kinked hoses and metal lines immediately.

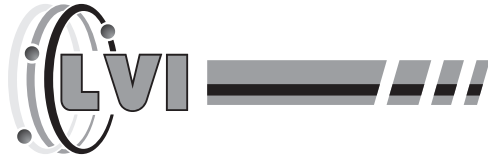

4. Do not attempt makeshift repairs to hydraulic lines, fittings or hoses by using tape, clamps or cements. The hydraulic system operates under extremely high pressure. Such repairs will fail suddenly and create a hazardous and unsafe condition.
5. Wear proper hand and eye protection when searching for a high-pressure hydraulic leak. Use a piece of wood or metal as a backstop instead of hands to isolate and identify leak. Do not attempt to repair a leak, but replace the hose instead.
6. If injured by a concentrated high-pressure stream of hydraulic fluid, seek medical attention immediately. Serious infection or toxic reaction can develop from hydraulic fluid piercing the skin.
7. Before applying pressure to the system, make sure all components are tight and that lines, hoses, and couplings are not damaged. Think SAFETY! Work SAFELY!

PRE-OPERATION CHECKLIST

Efficient and safe operation of the LVI LITTER PROCESSOR requires that each operator reads and understands all the operating procedures and all the related safety precautions outlined in this section.

1. Lubricate the machine as per the schedule in the Service and Maintenance section of the manual.
2. Use only tractor with adequate power to operate your LVI LITTER PROCESSOR.
3. Make sure the gearbox oil reservoir is filled to the proper level.
4. Check the gearbox. Make sure the drain plugs are properly installed and tightened and not leaking.
5. Make sure the chain case reservoir is filled to the proper level.
6. Make sure pivot points and bearings are greased.
7. Ensure that the machine is properly attached to your tractor.
8. Check the hydraulic system.
9. Inspect all hydraulic and oil lines, hoses, fittings and coupler for tightness.

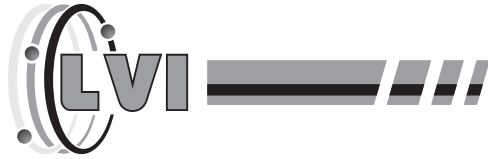

10. Check for and remove entangled material from the PTO, drive shaft and augers.
11. Check that PTO drive line is pinned to the tractor.
12. Check that shear bolt is installed and tight.
13. Close and secure all guards.

EQUIPMENT MATCHING

The LVI Deluxe model is designed to be used with agricultural tractors. To ensure a good performance, the following recommendations regarding minimum equipment size and horsepower should be met.

Model	PTO HP	Weight
Deluxe B Series	50 min	1520 lbs.

An operator must use his own discretion when determining whether the tractor attached is suitable. Using a small tractor on a heavy piece of machinery can cause severe injury or death if the operator loses control of the machinery.

PTO SHAFT INFORMATION

When the turner is attached to the tractor, the length of the PTO shaft should be such that proper overlap of the inner and outer tubes is maintained in all cases. See the attached section, located at the back of this manual, for PTO Shaft maintenance, trouble-shooting, and repair information. Note: Raising & lowering the 3pt arms & side shifting the turner will change the PTO shaft length.

The PTO shaft used for power transmissions between the power supply and the machine driven must not be used:

- without the guards
- with only partial protection
- with damaged guard

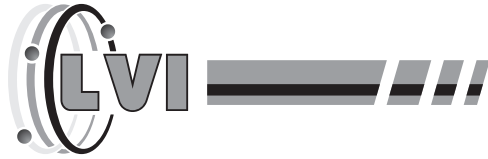

OPERATION

The LVI LITTER PROCESSOR is specifically designed to windrow poultry litter for in-house composting. Many of the features incorporated into this machine are the result of suggestions made by customers like you. Read this manual carefully to learn how to operate the machine safely and how to adjust it to provide maximum efficiency. Following the operating instructions with a proper maintenance program will extend the life of your machinery.

It is recommended to operate the processor at a slow steady speed. Creeper trans or hydro trans is recommended. The LVI LITTER PROCESSOR is designed to side shift left or right. This is primarily used when operating along the walls. It can be shifted while in operation. It is recommended to adjust the tilt when the tractor is not level.

After attaching the machine to the tractor, adjust top link length until the front of the processing machine is slightly higher than the rear of the machine. This is done to prevent rotor paddles from striking the floor. Also avoid allowing the front of the wing to gouge into the floor while driving forward.

General operating method is as follows: Run machine at 540 PTO RPM. Begin driving along outer wall of poultry house using the hydraulic side shift to have the wing tip closely follow the wall. It is recommended that the corner areas of poultry houses have the litter removed and spread down the center area before beginning the process. Proceed driving around the entire perimeter of the poultry house forming the litter into a windrow. Make a second round gathering the windrow along with fresh litter to form a double windrow.

After completing the second round, proceed down the center area of the poultry house to move material toward the previously formed windrows. The desired end result is to have two or three windrows down the length of the poultry house. Ideal windrows will be 22 inches to 32 inches in height. Allow windrows to set in this condition for 48 hours during which the center of the windrow should attain at least 130°F temperature. After this time period the windrows should be processed again with the litter processor. Accomplish this by driving the tractor and processor straddling the center of the windrow. If the tractor has a front end loader, raise the loader about 24" above the floor and use the loader bucket to partially flatten the top of the windrow which allow the tractor to travel over the windrow a bit easier. After the windrow has been processed a second time, allow it to set at least 48 hours to heat and compost.

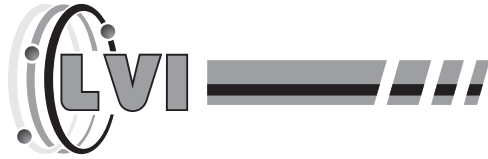

When final composting is accomplished the litter processor can be used to level the litter across the floor of the poultry house. Raise the machine and set the pin adjustable rear skid shoes for the desired depth of litter. Lower the machine till the skid shoes just touch the floor. Carry most of the weight of the machine with the tractor lift arms rather than entirely on the skid shoes. Run the machine at 540 PTO RPM. Drive in such away that the machine wing takes about 50% of the windrow and moves material toward the outside wall of the poultry house. Continue driving in various passes until all material has been leveled evenly across the poultry house floor.

Note: Confer with your poultry management team concerning the use of “poultry litter treatment” to reduce the presence of ammonia which could be detrimental to survival of young birds.

Should excessive loads be placed on the drive train, the shear bolt will break. This is a safety feature. Do not depend on this as the maximum load indicator. If the shear bolt does break, it must be replaced with the correct bolt specified by the manufacturer.

Note: Rocks, stones and other foreign objects can severely damage the machine. Avoid running these objects into the machine.

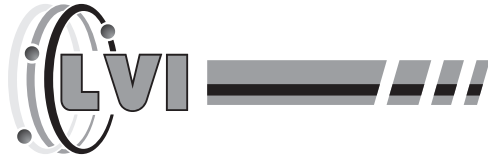

GEARBOX LUBRICATION

Oil level should be at bottom or within 1/2" of check plug. If no oil is visible, remove fill plug and fill with 80-90 EP GEAR OIL - GL-5 CLASSIFICATION. Be sure to reinstall plugs. Check oil level every 6 MONTHS.

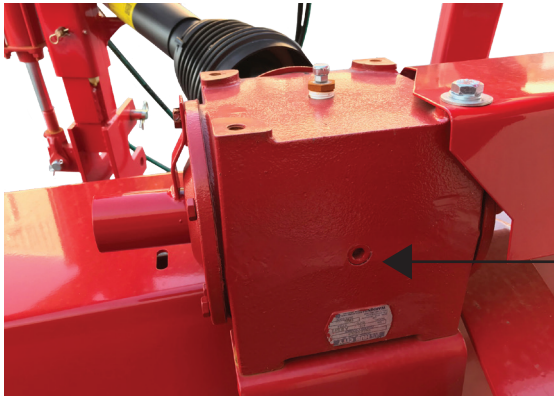

Oil Level Check Plug

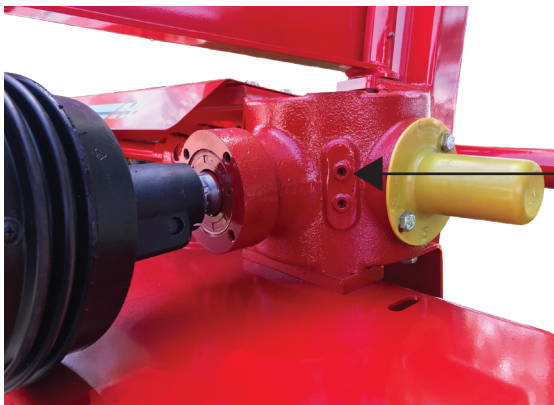

Oil Level Check Plug

GEARBOX LUBRICATION

Oil level should be **between the two check plugs**. If no oil is available, remove fill plug and fill with 80-90 EP Gear Oil - GL5 classification. Be sure to reinstall plugs. Check oil level every 6 months. Gearbox does not require a breather vent.

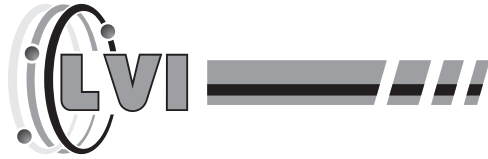

2 - Grease Zerk

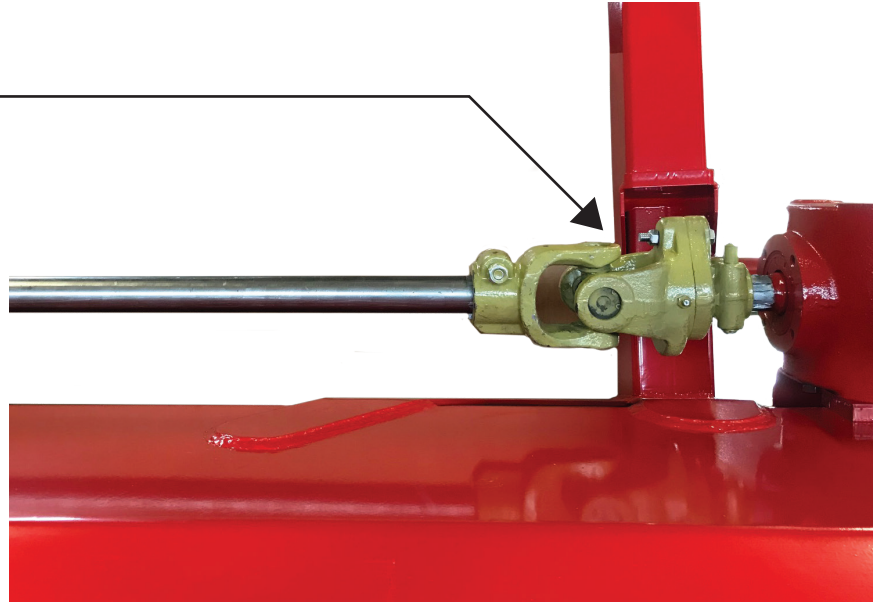

SHEAR BOLT & DRIVE LINE

The processor gearbox, chain case, and drive line are shear bolt protected. Should you encounter an obstruction in the rotor or auger and the shear bolt shears turn the tractor off and replace the shear bolt with a 3/8" X 2-1/2" GRADE 2 BOLT WITH 3/8" LOCK NUT. Do not tighten shear bolt excessively tight.

Shear Bolt

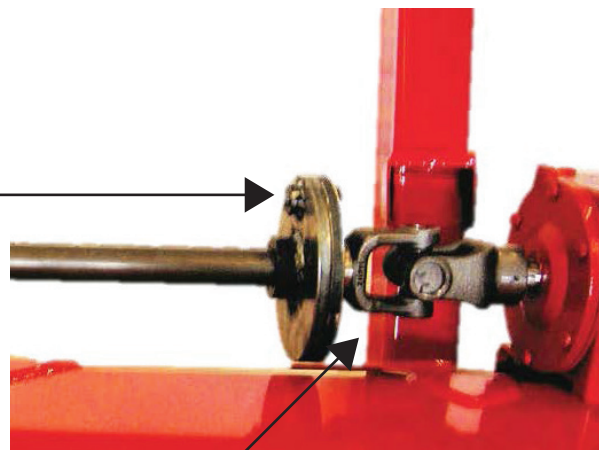

2 - Grease Zerk

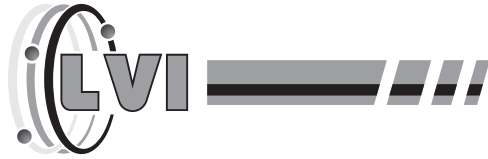

CHAIN CASE

The processor is equipped with an enclosed chain case for powering the rotor and auger. The oil level should be to the bottom of check plug. Check every 3 months. It is common to see some oil seepage where the rotor shaft enters the chain case. If oil level is not to bottom of check plug remove fill plug and fill with 80-90 gear oil. Be sure to reinstall plugs. The chain case has a drain plug on the bottom side if you should have to drain the oil.

To check chain tension, remove PTO Shaft from tractor and hold shear bolt assembly and turn rotor, there should be little play. Then hold rotor and turn auger, there should be little play. If there is too much play, open chain case and tighten chains. Reinstall chain case cover and fill with oil.

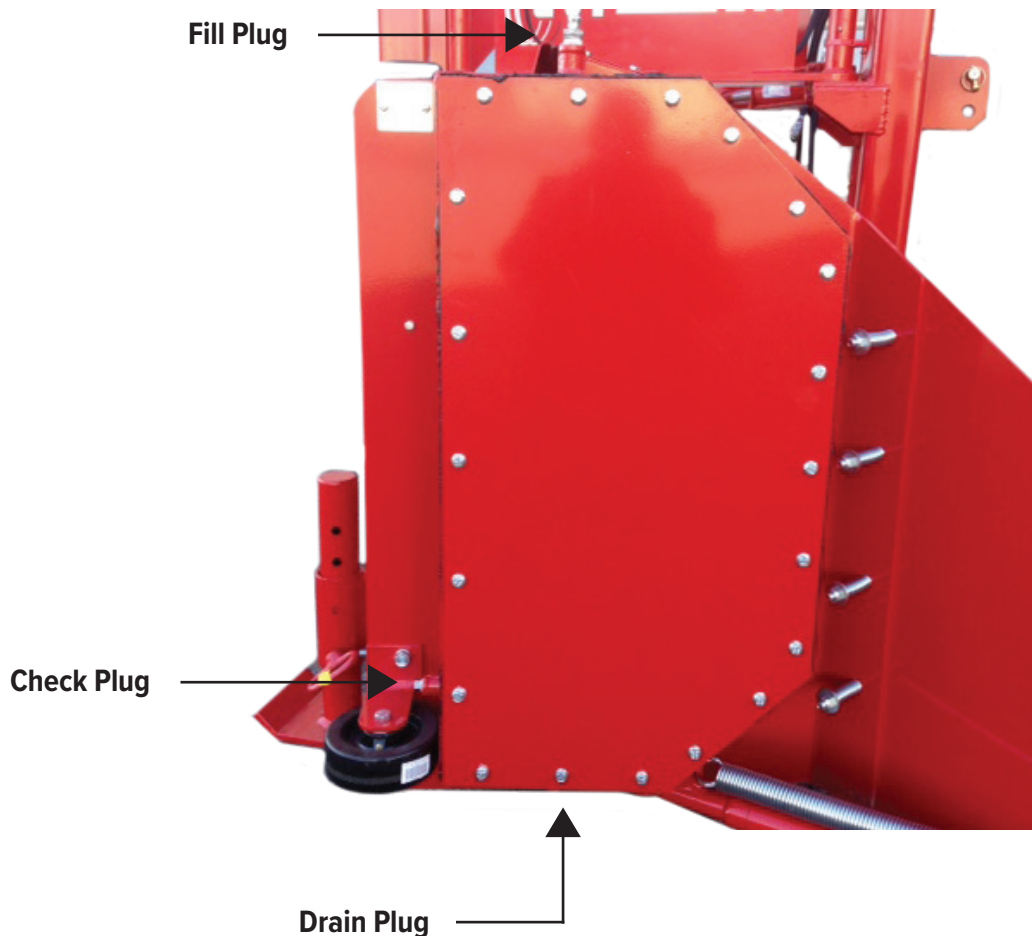

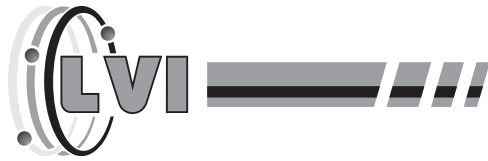

BEARINGS

There are two bearings to grease. Grease every 8 Hours.

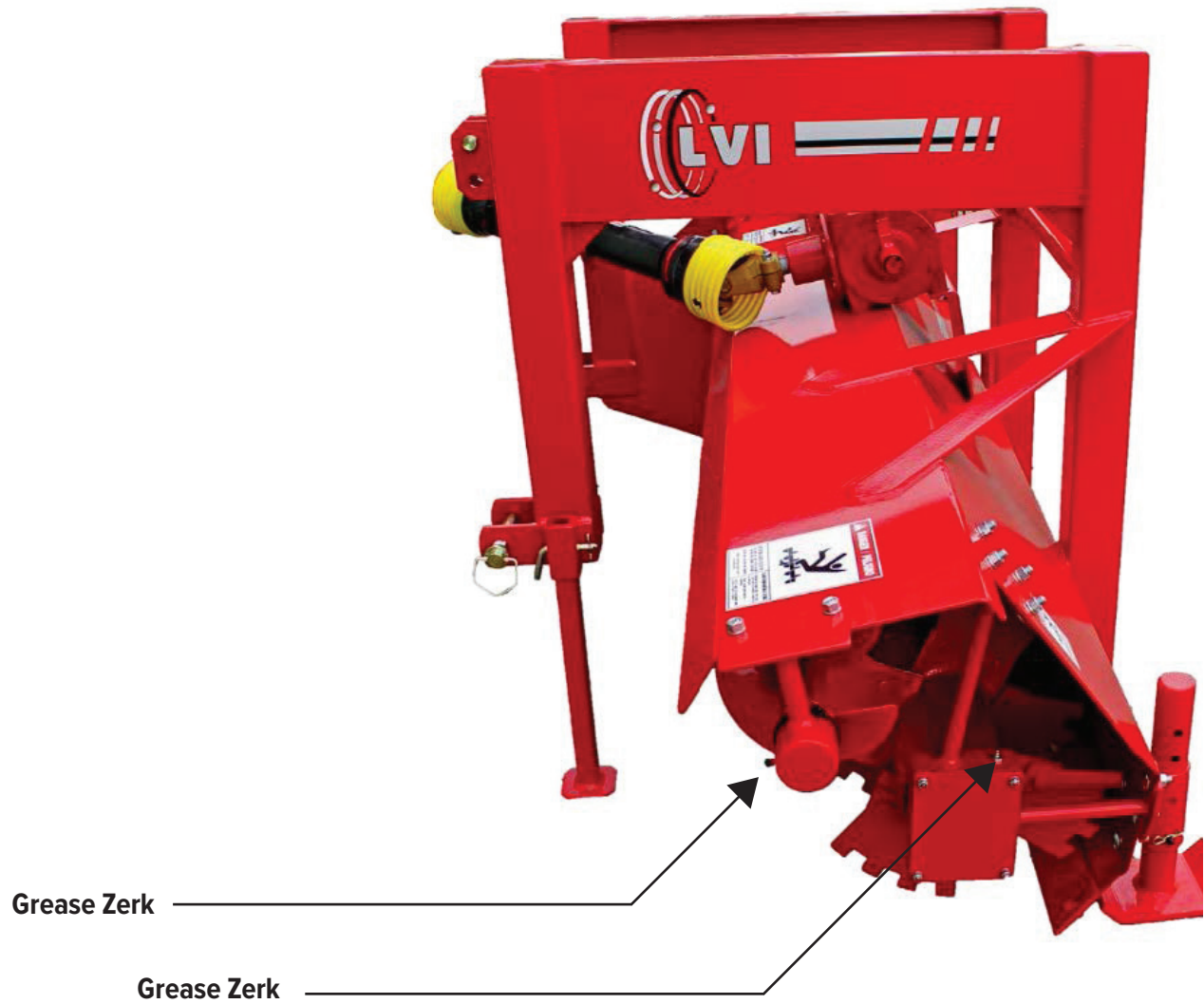

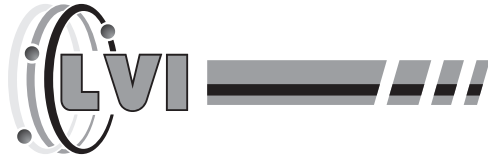

MAINTENANCE SCHEDULE

To ensure the long life for which the processor was designed, it is essential that the proper maintenance procedures are followed. The following chart indicates the manufacturer's recommended lubrication/maintenance schedule.

DESCRIPTION	HOURS OF OPERATION	SPECIAL INSTRUCTIONS	
GEAR BOX	CHECK EVERY 6 MOS	80-90EP GL-5 GEAR OIL	
CHAIN CASE	CHECK EVERY 3 MOS	80-90EP GL-5 GEAR OIL	
PTO SHAFT	The PTO should be greased according to the manufacturer's specifications.	(See attached PTO Information for proper maintenance procedures).	
BEARINGS	GREASE EVERY 8 HRS	QUALITY LITHIUM 2 GREASE	
SHEAR BOLT	WHEN BROKE	3/8" X 2 1/2" GRADE 2-W/LOCK NUT	
SHEAR BOLT PLATE	GREASE EVERY 20 HRS	2-PUMPS QUALITY LITHIUM 2 GREASE	
DRIVE LINE	GREASE EVERY 20 HRS	2 PUMPS QUALITY LITHIUM 2 GREASE	

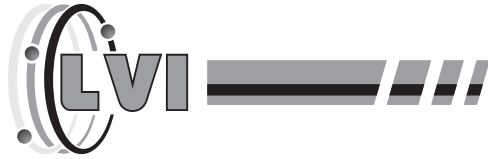

INDEX

Basic Views of Machine	Pg. 18
Serial/Model Plate.....	Pg. 23
Shear Bolts.....	Pg. 24
Scraper Bar	Pg. 25
Paddles	Pg. 26
Wing	Pg. 27
Side Wheel.....	Pg. 30
Skid Shoe.....	Pg. 32
Bearings	Pg. 34
Sprockets.....	Pg. 35
Snap Ring.....	Pg. 36
Drive Chains.....	Pg. 39
Upper Main Drive Shaft.....	Pg. 43
Shear Bolt Assembly.....	Pg. 44
Gear Box	Pg. 46
Ball Bearing Unit.....	Pg. 50
Bearing Box.....	Pg. 54
PTO Shaft.....	Pg. 63
Warranty Forms.....	Pg. 74

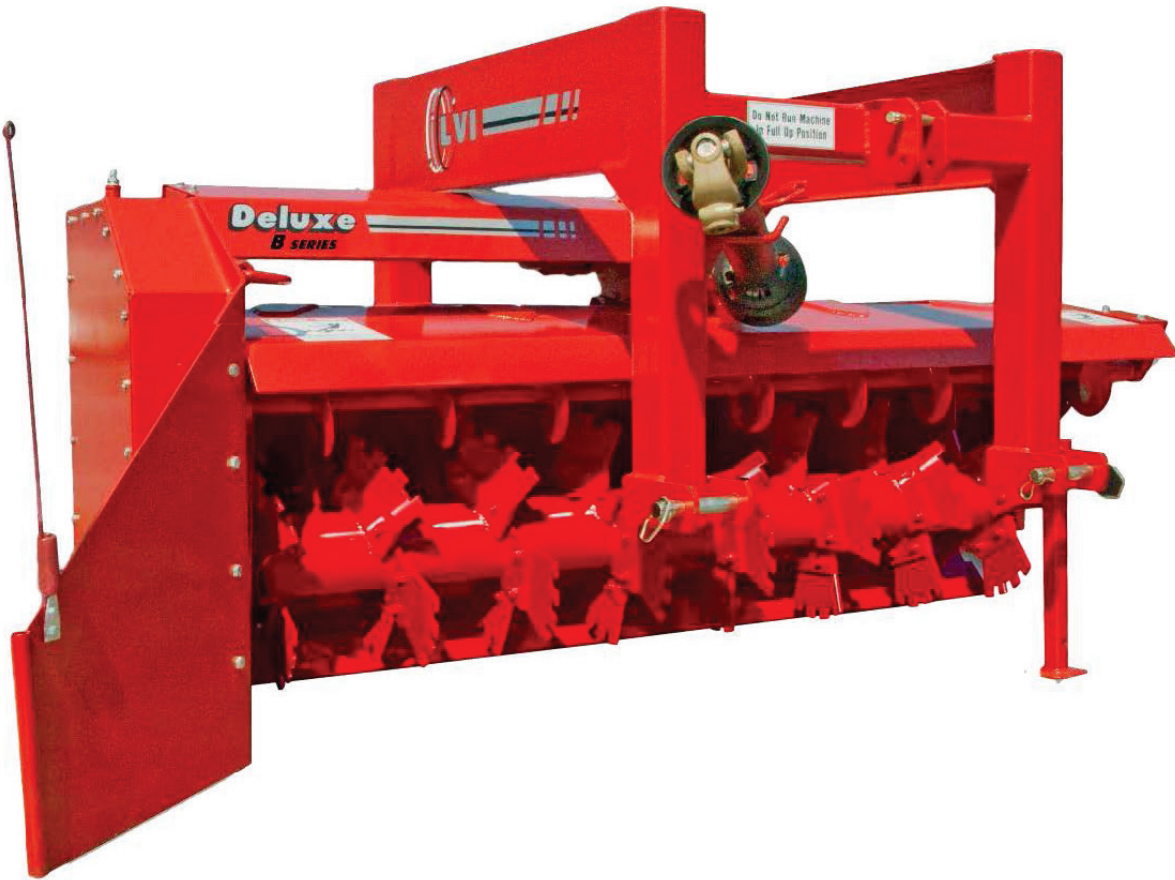
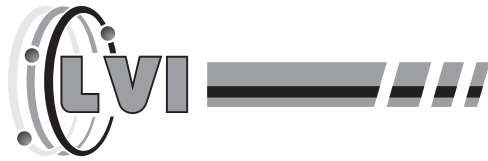

CENTER VIEW

Top link attaching pin #LTFX00076

Bottom link attaching pin (2) #LTFX17900

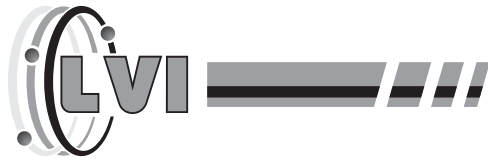

RIGHT VIEW

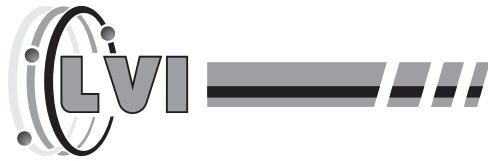

BACK VIEW

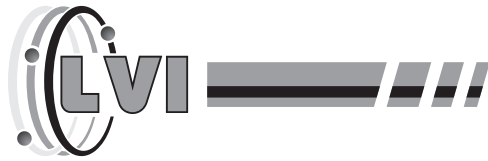

LEFT VIEW

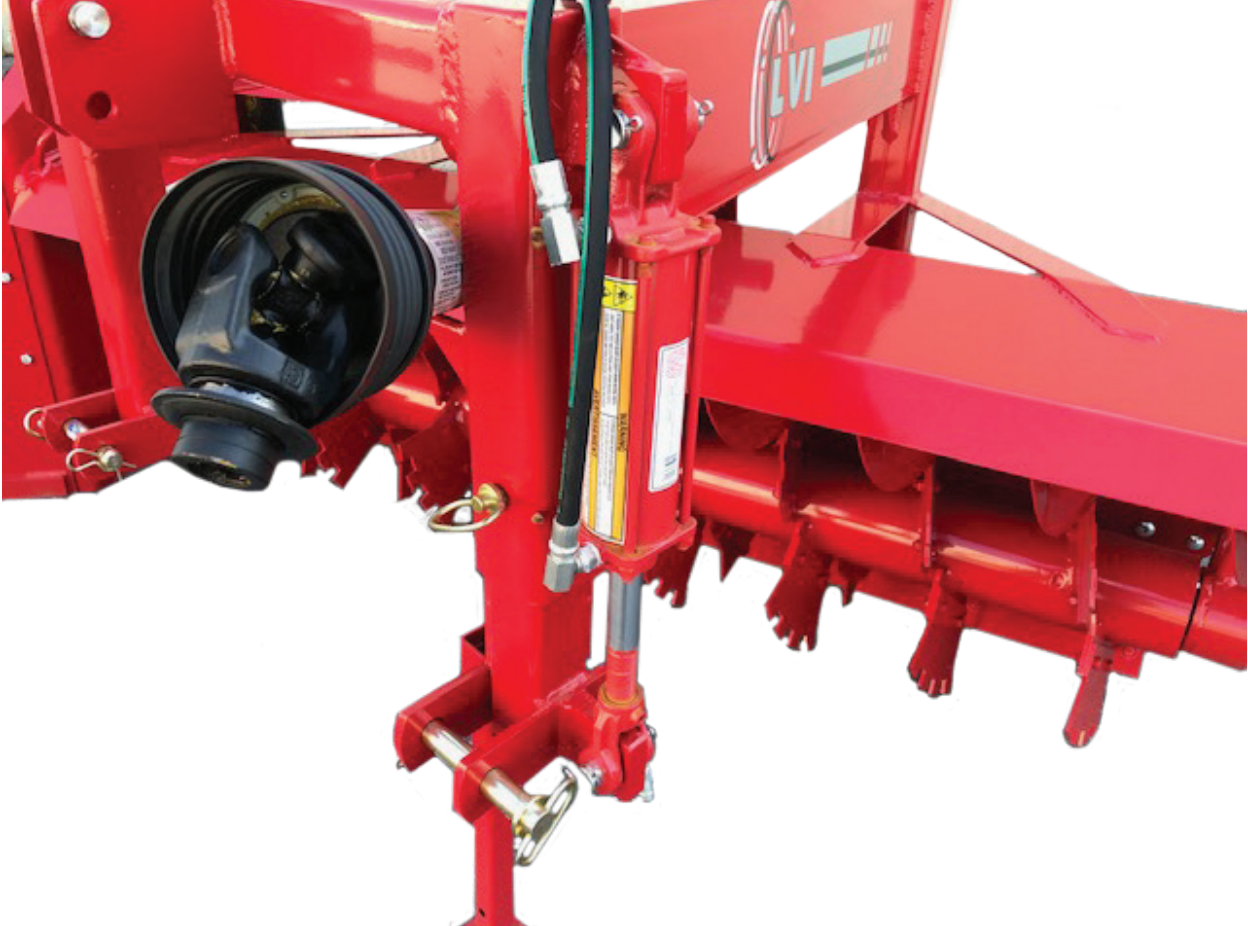
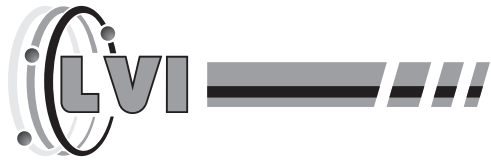

HYDRAULIC CYLINDER

#LT200105

Pins for hydraulic cylinder #LT200106

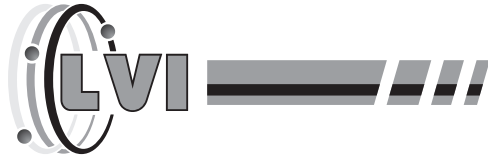

MODEL / SERIAL PLATE

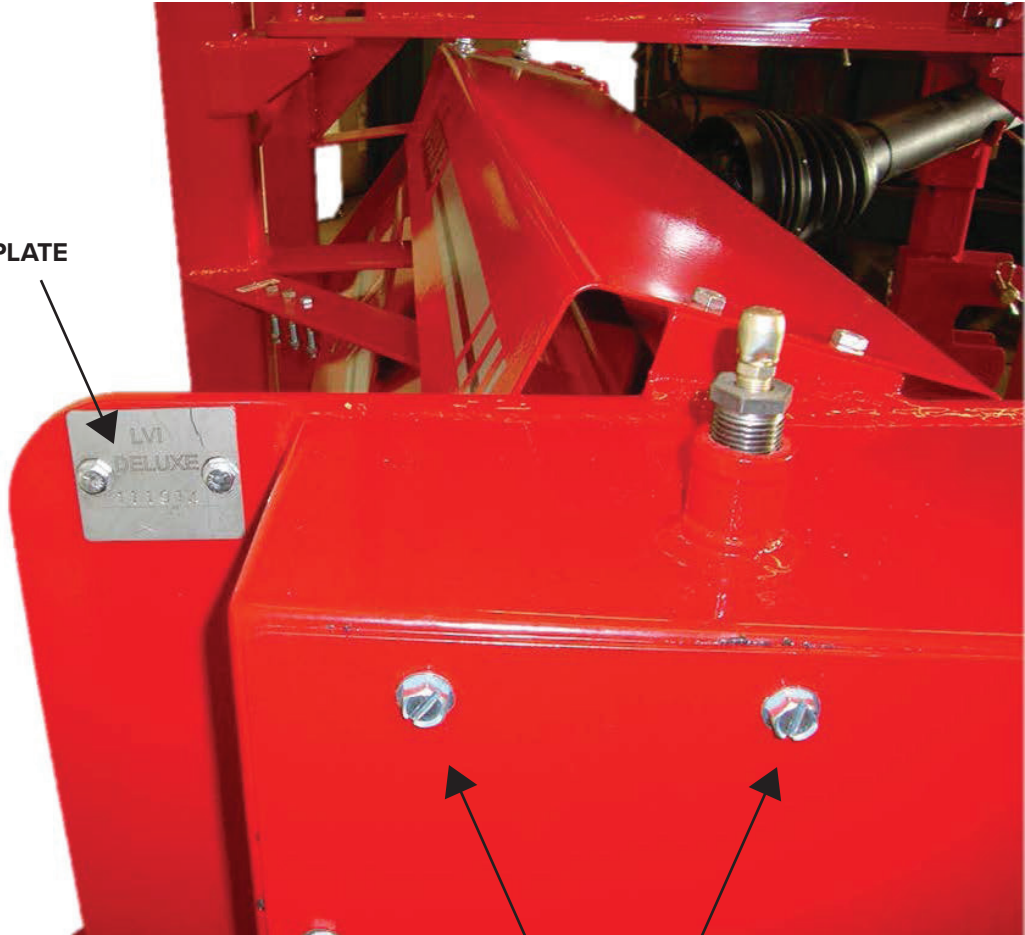

MODEL / SERIAL PLATE LOCATION & CHAIN CASE

Self-Threading Bolts Retain Lid to Chain Case.
#LT365053X1 (20)

Breather fitting top of chaincase #LT 190729M91

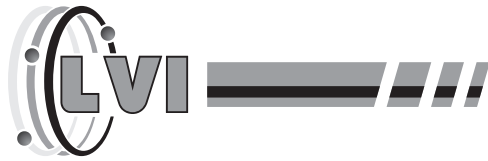

SHEAR BOLTS

3/8 x 2 1/2" gr.2 bolt

3/8" Lock nut

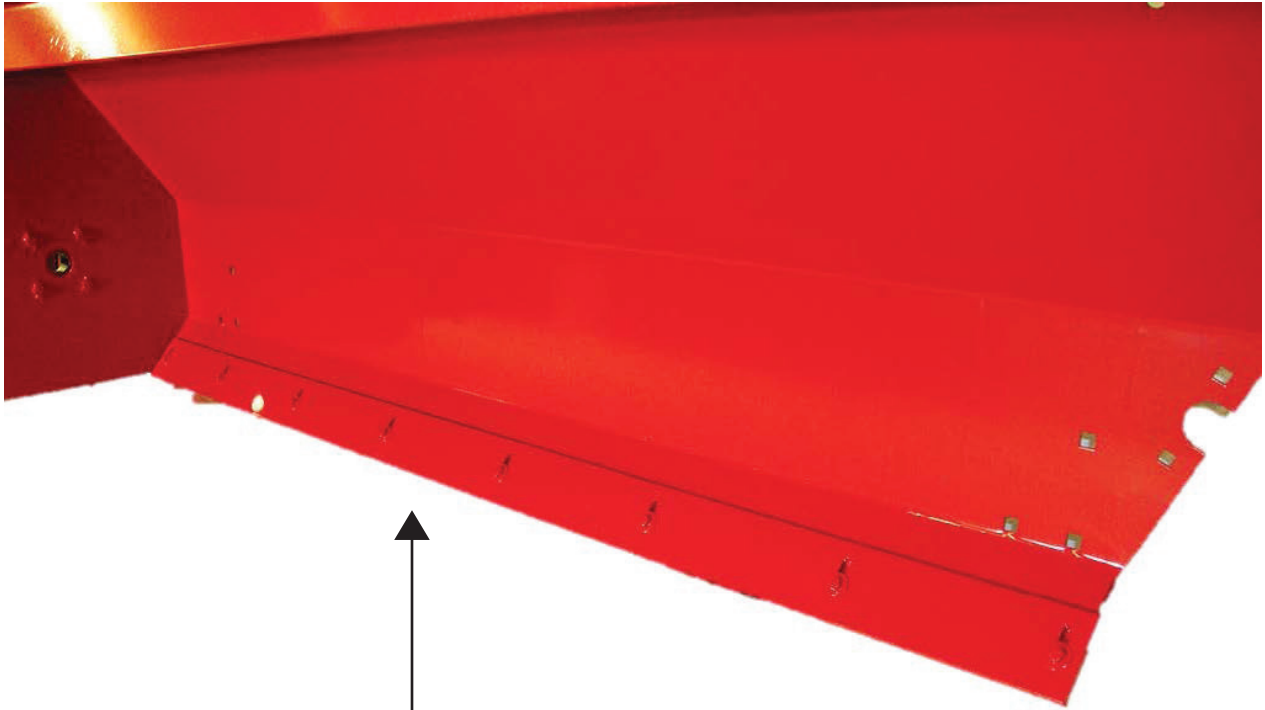
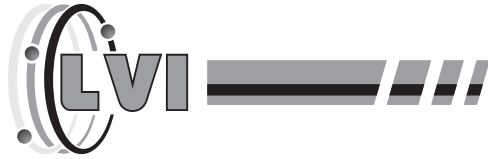

SCRAPER BAR #LT09250811

Retained by:

(8) - 7/16 X 1 1/4" Bolts gr.5

(8) - Lock washer

(8) - Flat washer

(8) - 7/16" Nut

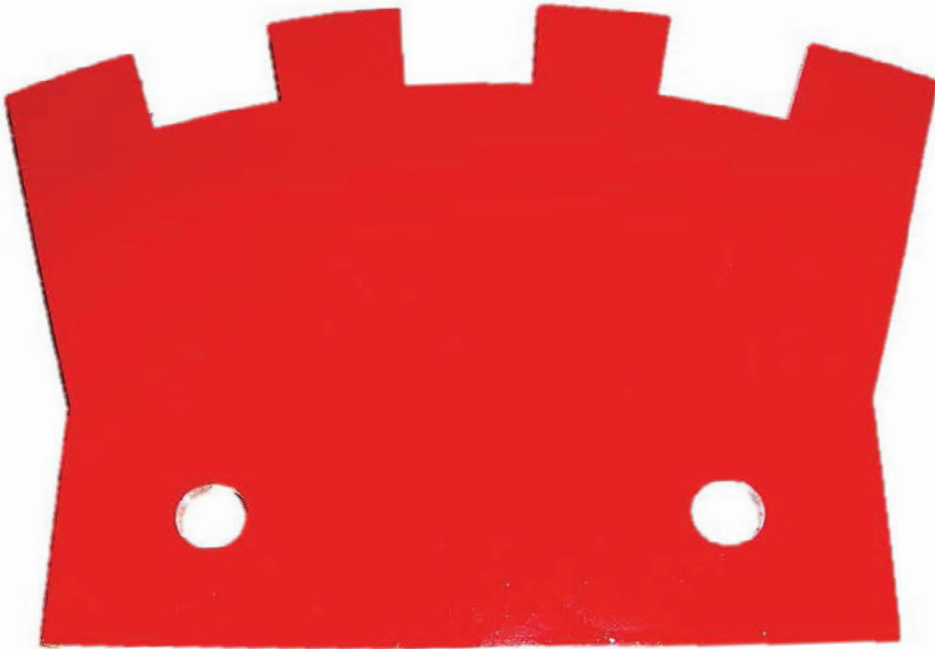
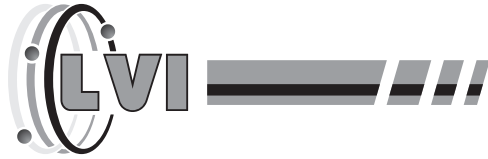

34 PADDLES

#LT0925081 - 1/4" thick - normal use

#LT0925081HD - 5/16" thick - heavy duty use

#LT0925081AR 3/8 - 3/8" thick abressive resistant

Attached with:

1/2" x 1 1/4" hex bolt

1/2" lock nut

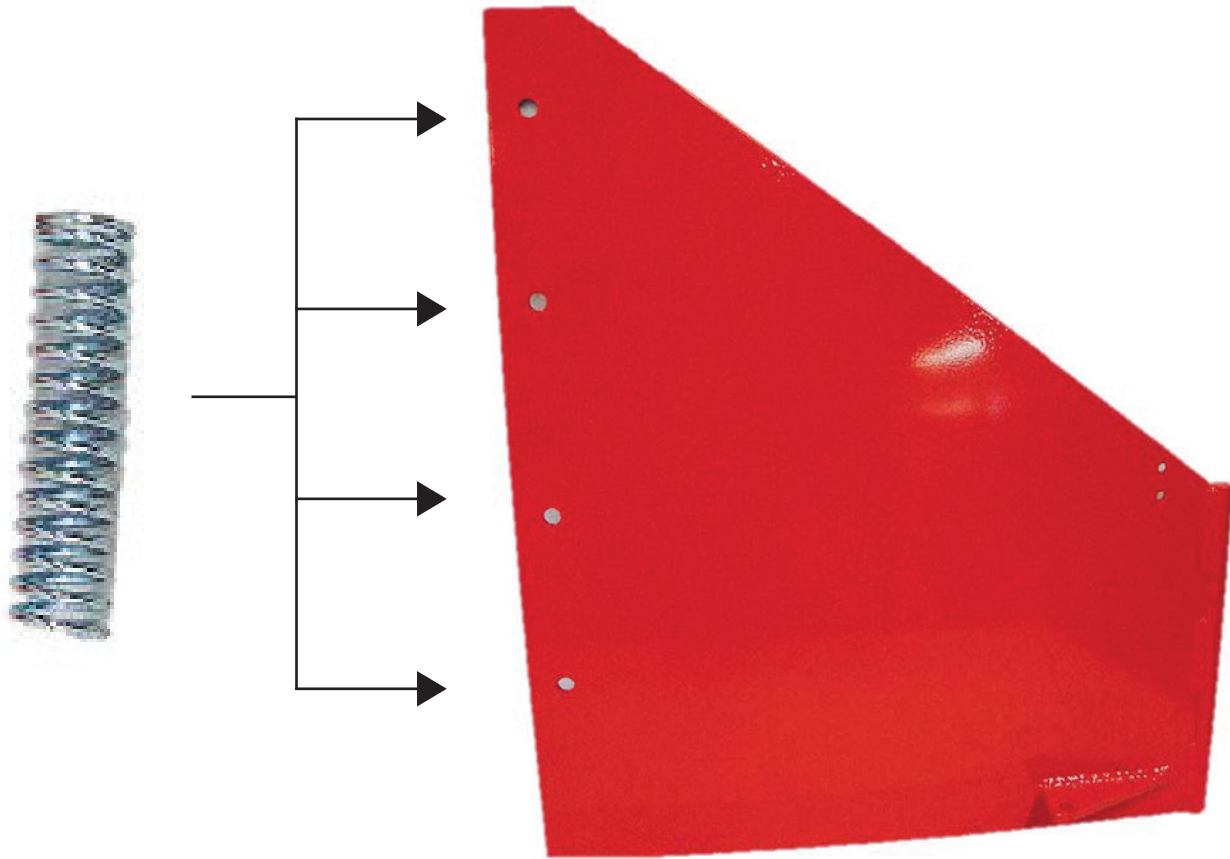
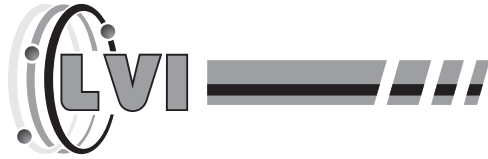

WING – RIGHT END OF MACHINE #LT050114

#LTC790, coil springs

4 - coil springs used on wing mounting bolts

(4) - 1/2" x 4" bolts

(4) - 1/2" lock nuts

(4) - 1/2" flat washers

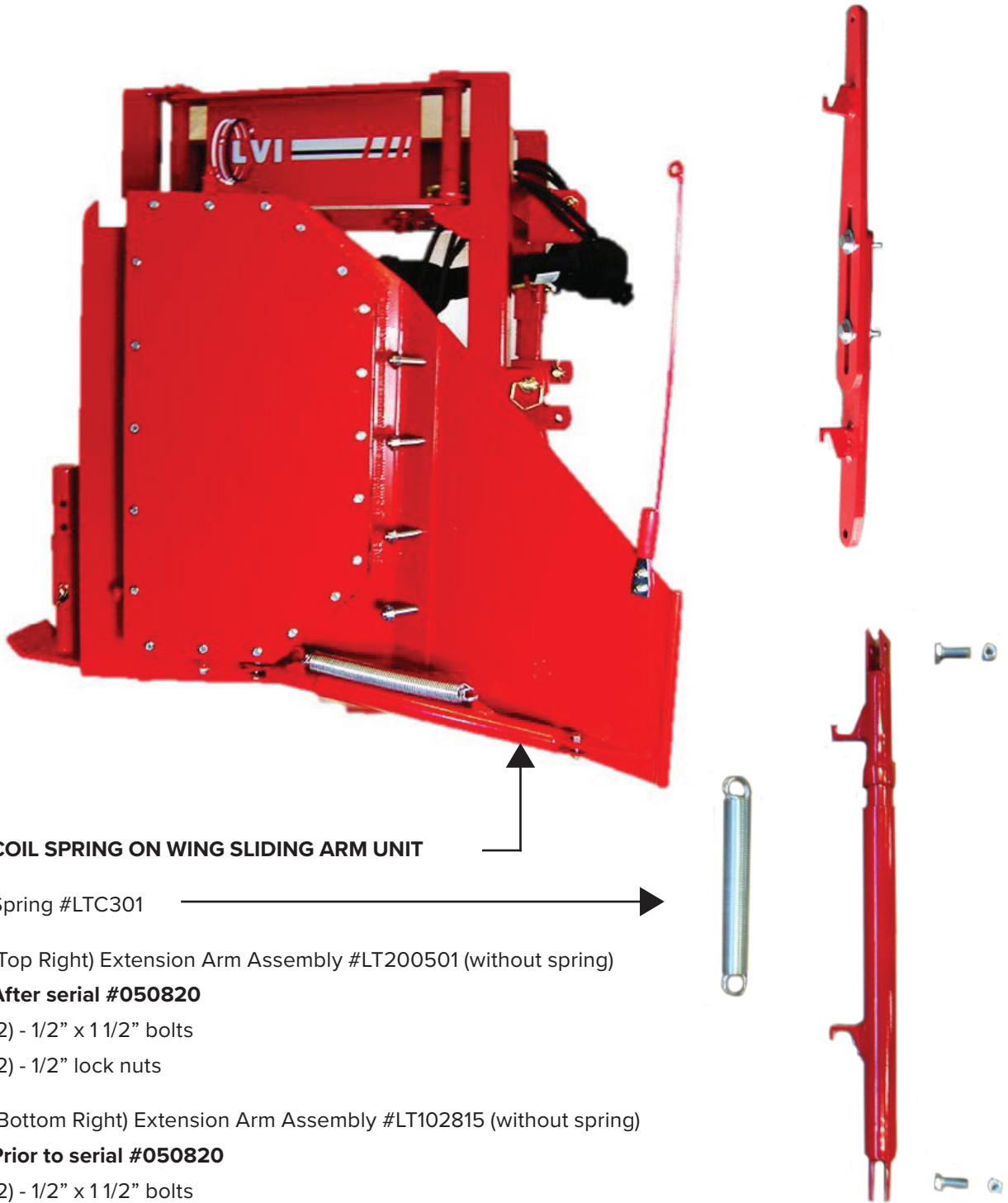
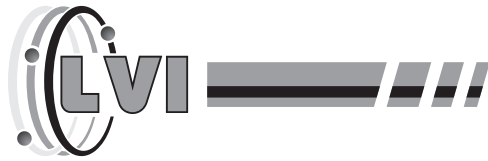

COIL SPRING ON WING SLIDING ARM UNIT

Spring #LTC301

(Top Right) Extension Arm Assembly #LT200501 (without spring)

After serial #050820

(2) - 1/2" x 1 1/2" bolts

(2) - 1/2" lock nuts

(Bottom Right) Extension Arm Assembly #LT102815 (without spring)

Prior to serial #050820

(2) - 1/2" x 1 1/2" bolts

(2) - 1/2" lock nuts

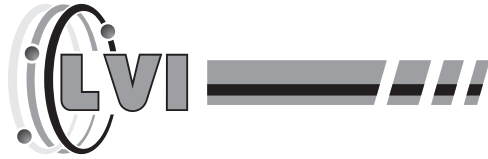

LID/COVER (POWDER COATED)

Lid/Cover #LT081617

Bolts

(20) - 5/16" x 3/4" flange head bolt #LT365053X1

Silicone sealant (1 Squeeze Tube) #LT586198

Marker Whip #LT62265

(2) - 5/16" x 1" bolts

(2) - 5/16" lock nuts



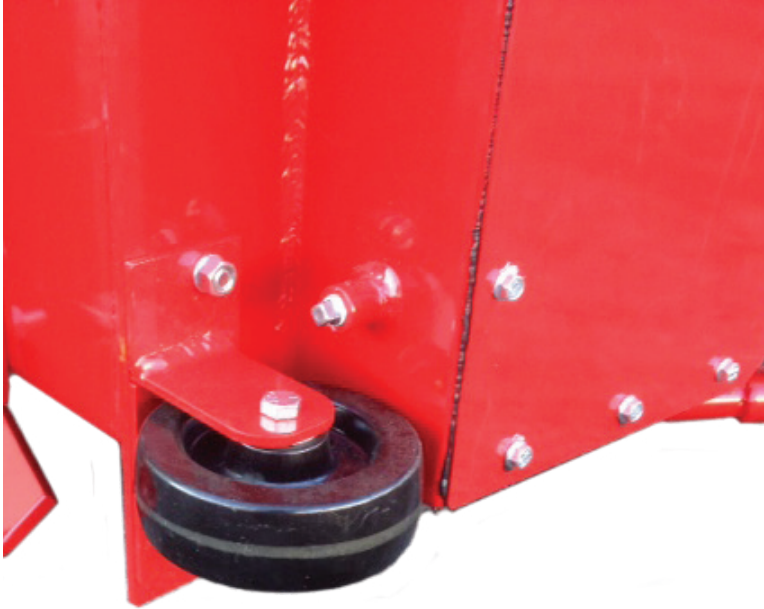
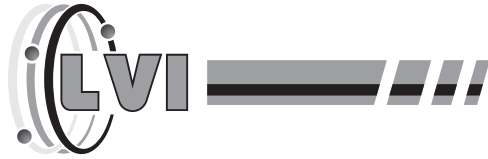

SIDE WHEEL

- (1) - Wheel #LT16V369
- (1) - 1/2" x 3 1/2" bolt and lock nut
- (1) - Bracket #LT120816
- (4) - 1/2" x 1 1/4" bolts
- (4) - 1/2" nuts
- (4) - 1/2" lock washers

COMPLETE KIT #LT120216

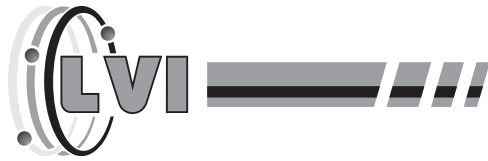

WING WHEEL

- (1) - Wheel #LT16V369
- (1) - 1/2" x 3 1/2" bolt and lock nut
- (1) - Bracket #LT120716
- (4) - 1/2" x 1 1/4" bolts
- (4) - 1/2" nuts
- (4) - 1/2" lock washers

COMPLETE KIT #LT120416

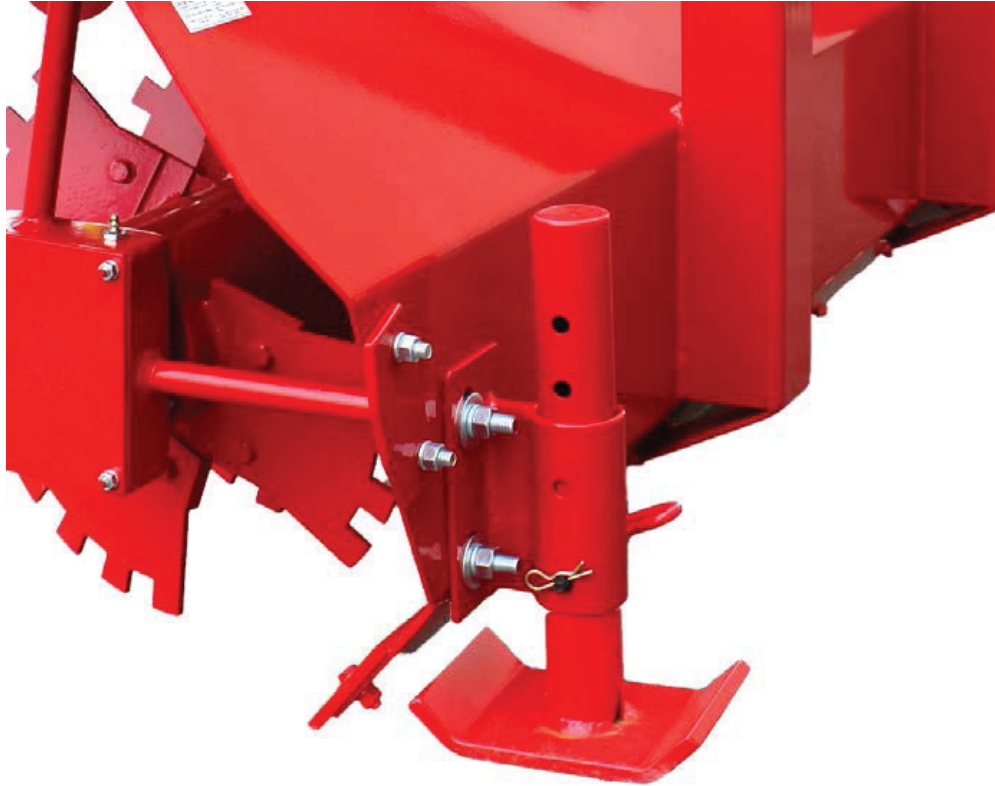
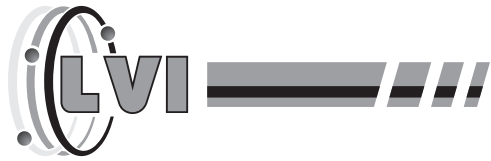

SKID SHOE

Skid shoe pin #LTFX01500

Skid shoe before serial #082717 #LT121714

Skid shoe after serial #082717 #LT121314

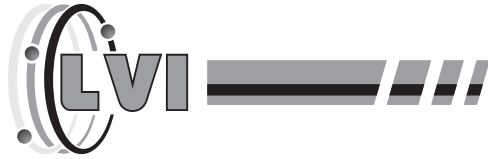

MOUNTING BRACKET – SKID SHOE

#LT121214

Retained with:

- (3) - 5/8 x 2" gr.5 Carriage bolts
- (3) - 5/8" Flat washers
- (3) - 5/8" Lock washers
- (3) - 5/8" Nuts

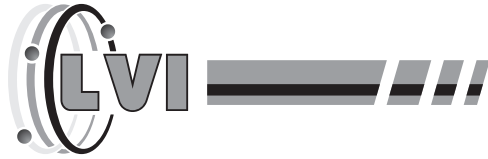

BEARINGS

Drive shaft

Top - #LTB1124 - 1 1/2" diameter with lock collar

- (4) - 9/16" x 2" bolt
- (4) - 9/16" nut
- (4) - 9/16" lock washer

Auger

Middle - #LTB1144 - 1 1/4" diameter with lock collar

- (4) - 1/2" x 2 1/2" bolt
- (4) - 1/2" nut
- (4) - 1/2" lock washer

Rotor

Bottom - #LTB1344 - 1 3/4" diameter with lock collar

- (4) - 5/8" x 2 1/2" bolt (welded to frame)
- (4) - 5/8" nut
- (4) - 5/8" lock washer



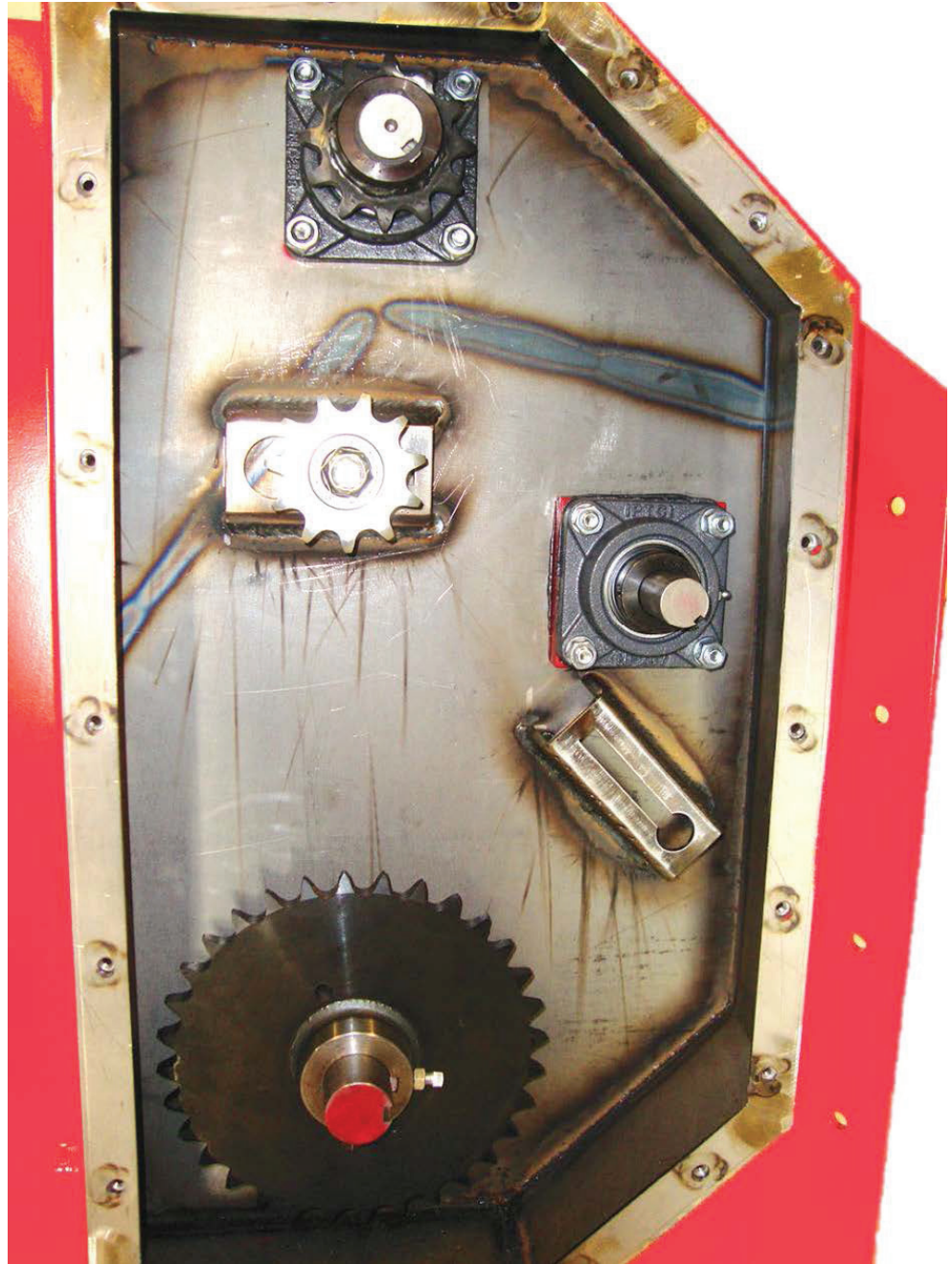

DRIVE SPROCKETS FOR MAIN ROTOR-SEE NEXT PAGE

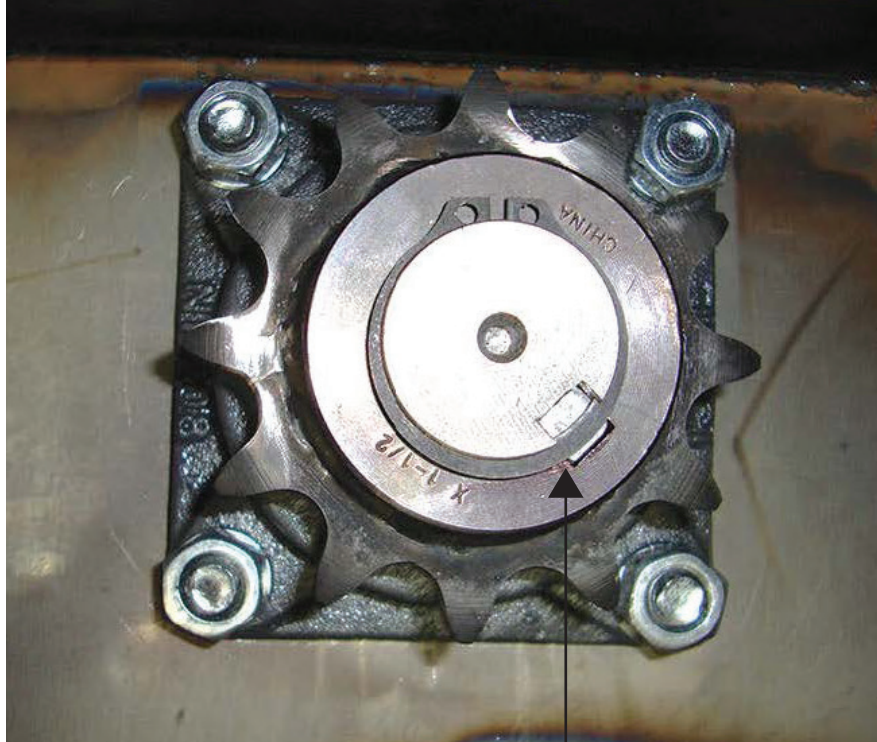
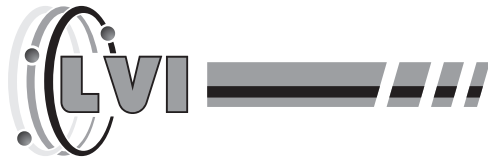

SNAP RING

#LTSRE112

Top Drive Sprocket #LTS8012112

#80 12 Tooth 1 1/2 I.D.

3/8 Key Way

#LT3838112 Hardened Key

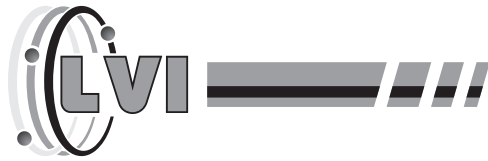

BOTTOM ROTOR DRIVE SPROCKET

#LTS8032134

#80 32 tooth

(2) - 3/8" coarse thread allen wrench set screw

1 3/4" I.D.

7/16" key way

Drive Key #LT716716178, hardened

*Early machines (prior to 2013) had 3/8" key way

*Put red locktite into set screw holes when installing sprocket

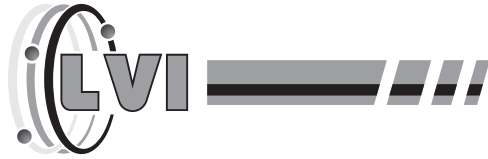

IDLER SPROCKET

#LTS801134

#80 11 Tooth

Retained By:

3/4" x 3 1/2" gr.5 carriage bolt, #LT5C3/4x31/2C

1 1/2" long spacer behind sprocket, #LT120117

3/4" lock nut, LTSLN 3/4" c

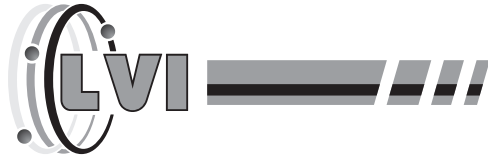

DRIVE CHAINS

#80, Main Drive
72 rollers, #LTRC8072

#60, Top Auger Drive
62 rollers, #LTRC6062

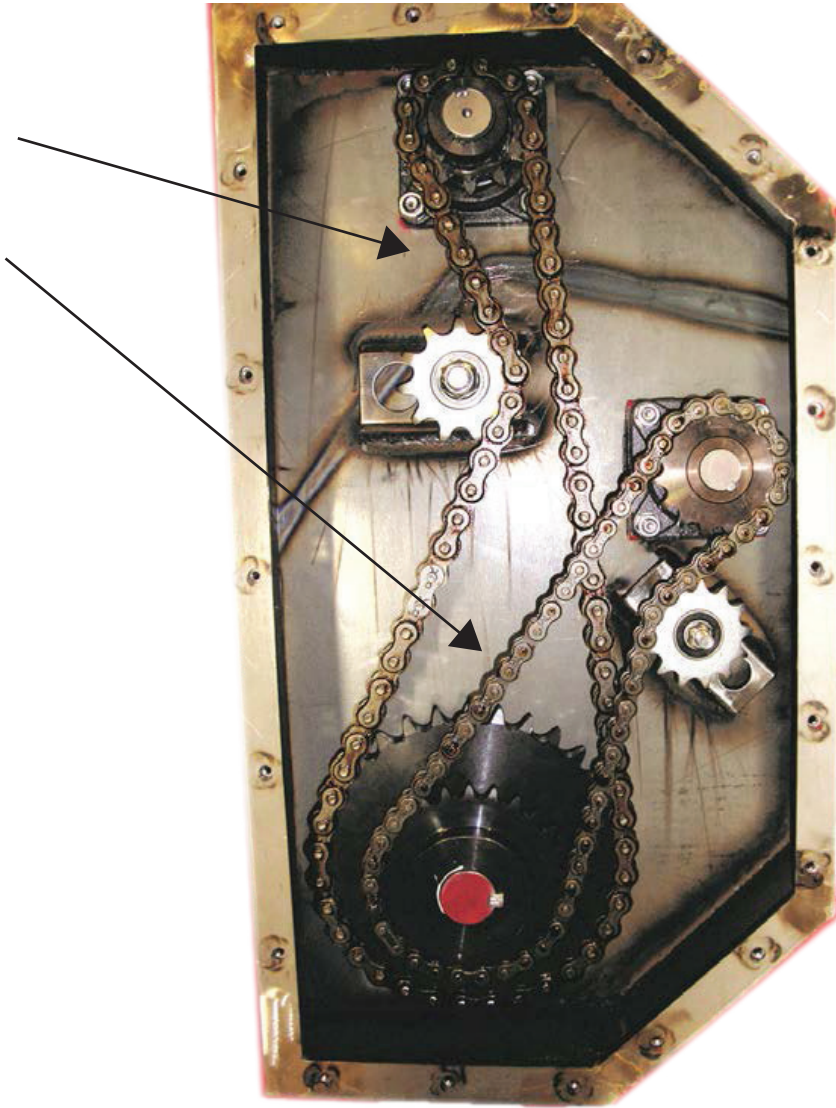

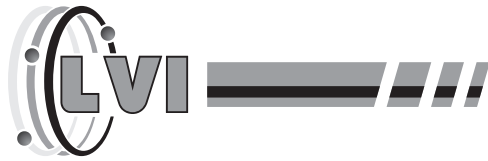

BOTTOM AUGER DRIVE SPROCKET

#LTS6026134716

#60 26 Tooth

1 3/4" I.D.

7/16" Key way

Drive key #LT716716114, hardened

Early Machines May Have 3/8" Key way prior to #010113

*Put red locktite into set screw holes when installing

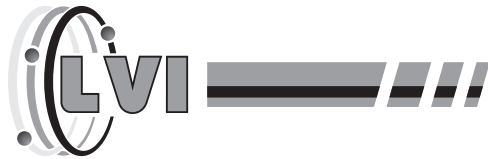

IDLER SPROCKET

#LT601312

#60 13 Tooth

Retained By:

1/2" x 4 gr.5 carriage bolt, #LT5C1/2x4C

1/2" lock nut, #LTSLN 1/2 c

Spacer behind sprocket

#LT120217

1 3/4" long

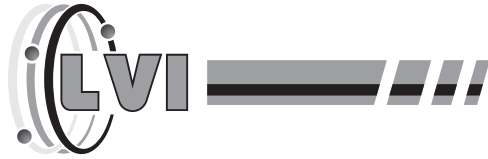

UPPER AUGER DRIVE SPROCKET

#LTS6016114

#60 16 Tooth

1 1/4" I.D.

1/4" Key way

Drive key, hardened #LT1414112

Snap ring #LTSRE114

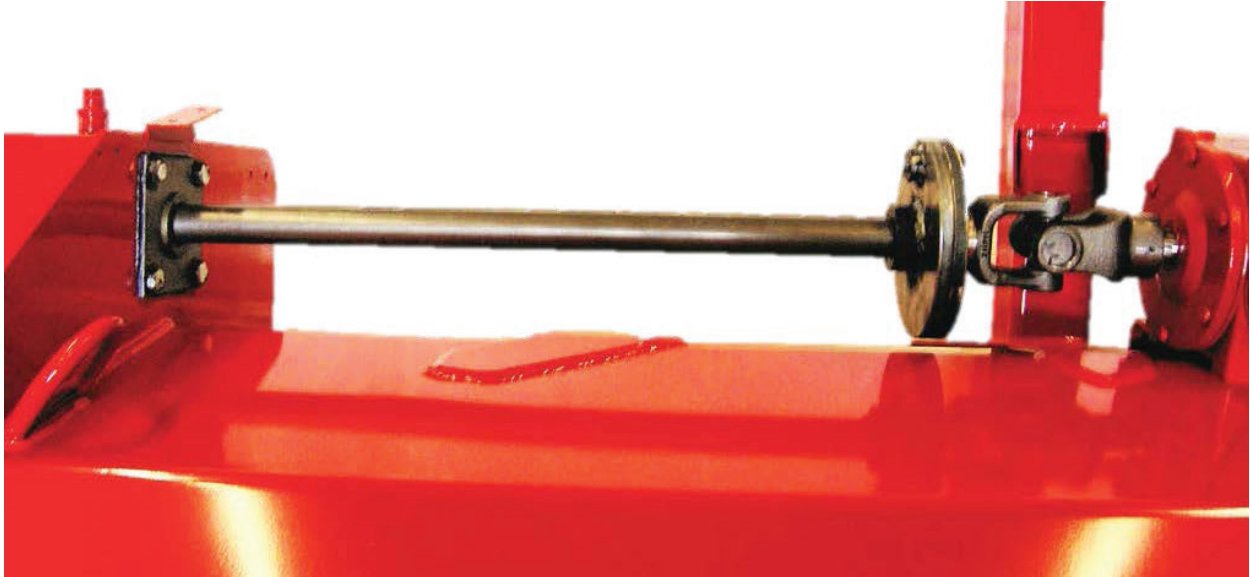
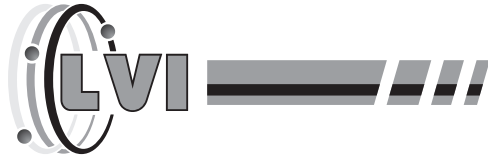

UPPER MAIN DRIVE SHAFT

Prior to serial #050820

- Upper main drive shaft from center gearbox out to chain case
- For shear bolt and U joint next to gearbox, see “shaft bolt unit” page
- For information on main drive shaft according to SNs see drive shaft page

After serial #050820

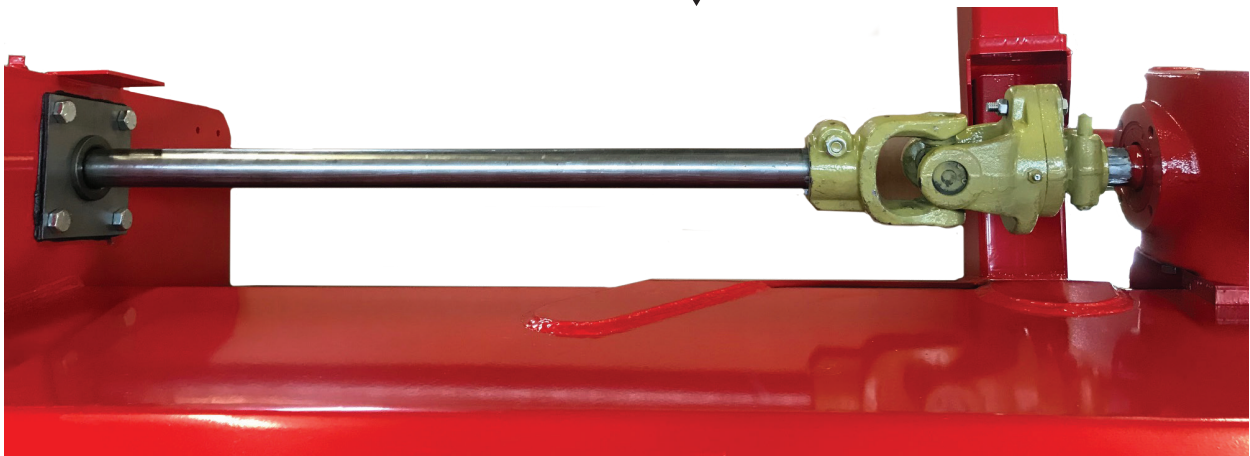

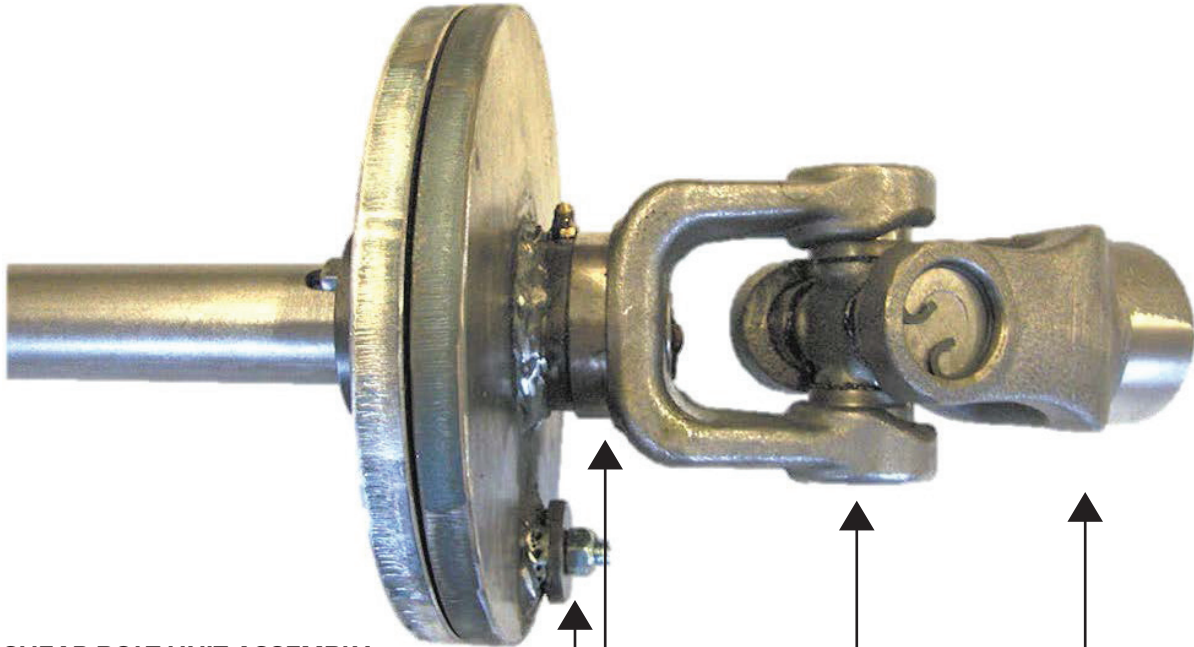
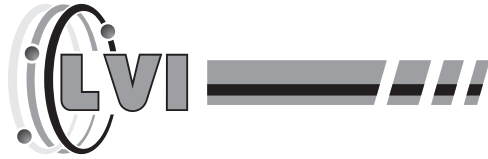

SHEAR BOLT UNIT ASSEMBLY

#LT102915

Prior to serial #050820

Shear bolt 3/8" x 2 1/2" grade 2, 3/8" lock nut

#LT060114 bronze bushing

#LT060214 35 series cross kit

#LT060314 35 series yoke, 5/16" key way, 1 3/8" RND I.D.

Drive key #LT5165162, hardened

Shear bolt unit after serial #050820

Shear bolt 3/8" x 2 1/2" gr. 2, 3/8" lock nut

Cross kit #6 series #MA600

Complete unit #LT79X562BC

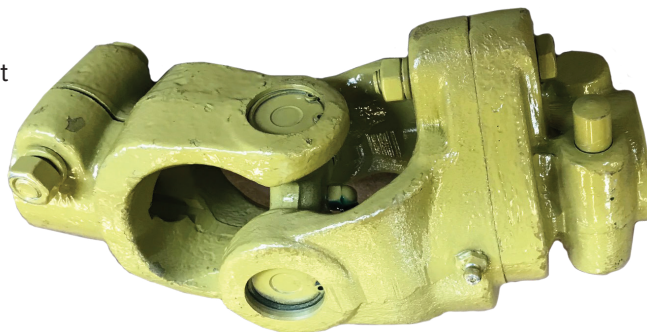

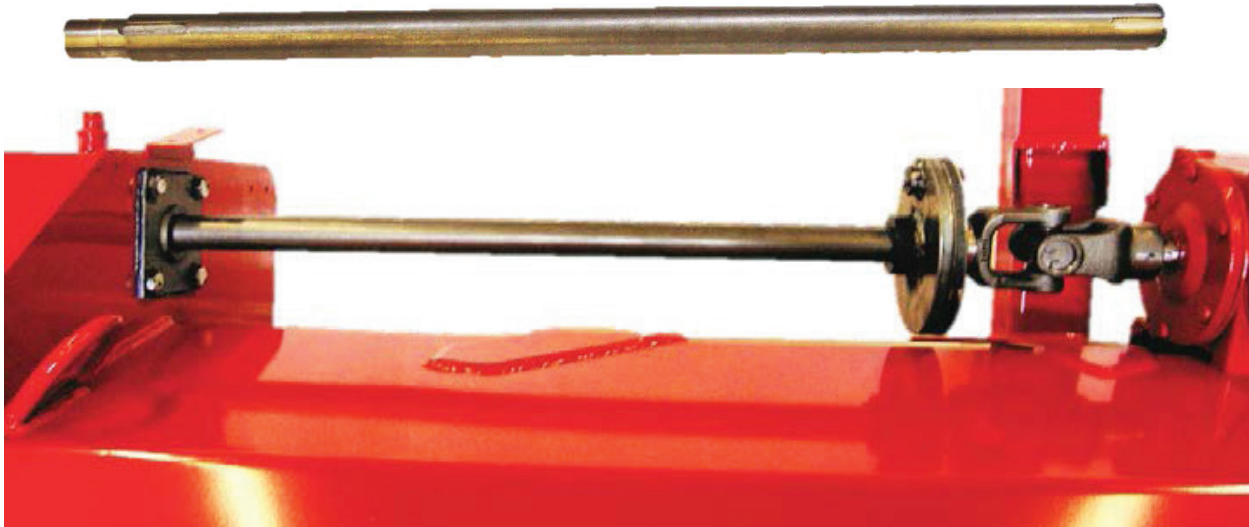
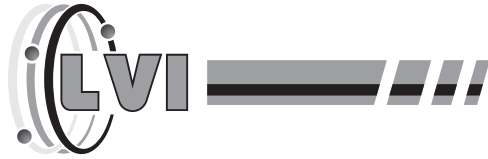

TOP MAIN DRIVE SHAFT

- Prior to serial #081514 shaft length = 36 5/8", #LT123014A
- Serial #081514 to #082717 shaft length = 36", #LT123014
- Serial #082817 to #050820 shaft length = 39 1/4", #LT191417



TOP MAIN DRIVE SHAFT

- After serial #050820, Shaft length = 38 1/8", #LT210201

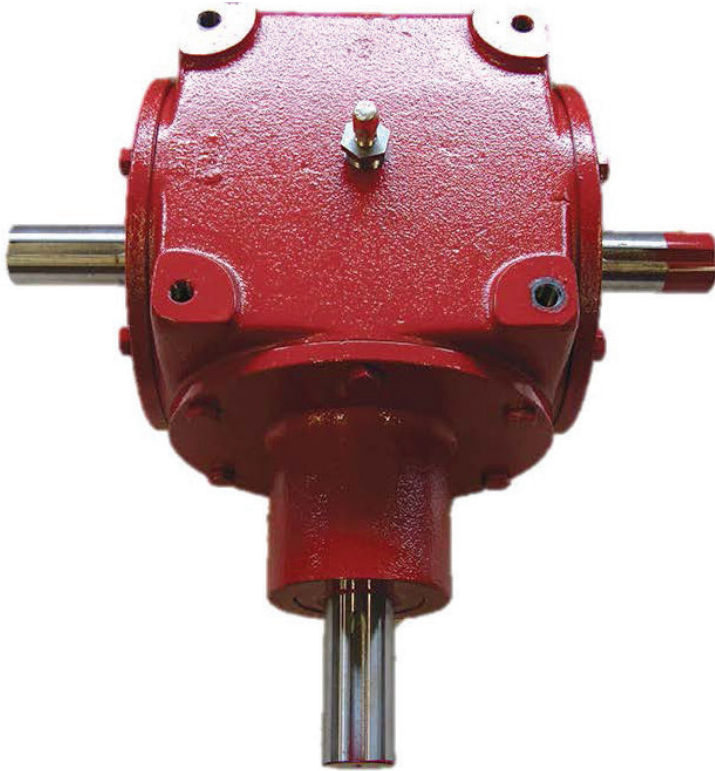
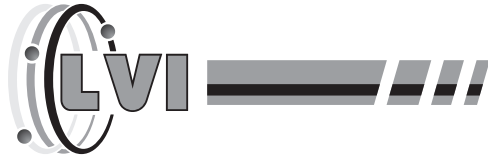

GEARBOX

Prior to serial #050820

#LT0220-04004

1 3/8" diameter shafts have 5/16" key way

#LT132563TB oil seal-input shaft

#LT181872TB oil seal-output shaft

#LT190729M91 breather fitting

#LT44236 1/2" x 1/8" NPT bushing

Drive key (2) LT5165162, hardened



SHAFT COVER

#LT200201

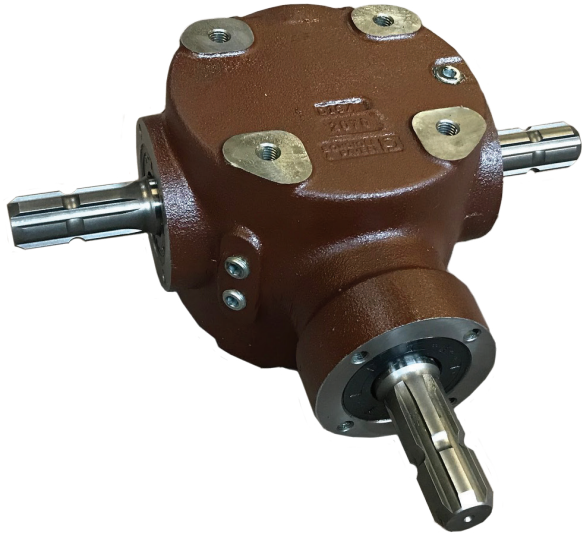
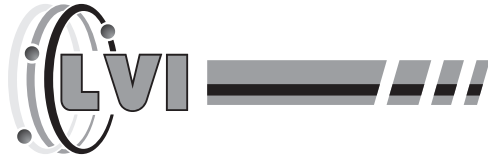

GEARBOX

After serial #050820

#LTS2070100G111

Shaft oil seal (all 3 are the same)

#LT103019



SHAFT COVER

#LT200701

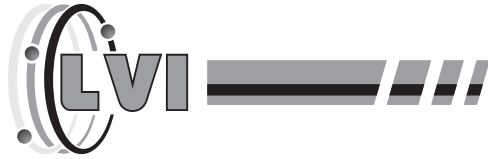

TOP AUGER ASSEMBLY

#LT053014



UPPER AUGER DRIVE SHAFT

#LT121414

1 1/4" diameter

1/4" key way



UPPER AUGER END SHAFT

#LT121514

- After SN 010114 - 1 3/16" smooth round shaft used ball bearing assembly

- Prior to SN 010114 15/16" smooth round shaft used bushing assembly*



* If replacing #LT121514 change to ball bearing assembly

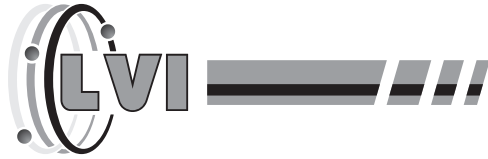

OUTER END OF TOP AUGER BUSHINGS

-Prior to SN 010114

White plastic bushing

#LT35443431



Brown phenolic bushing

#LT051014



BUSHING BEARING UNIT FRAME

- Prior to SN 010114

#LT020915



*Ball bearing arrangement in use after SN 010114

SEE NEXT 2 PAGES

Ball bearing update kit is available #LTAUGERBEARINGKIT

Converts to ball bearing design (need to weld new shaft into auger tuber supplied with kit)

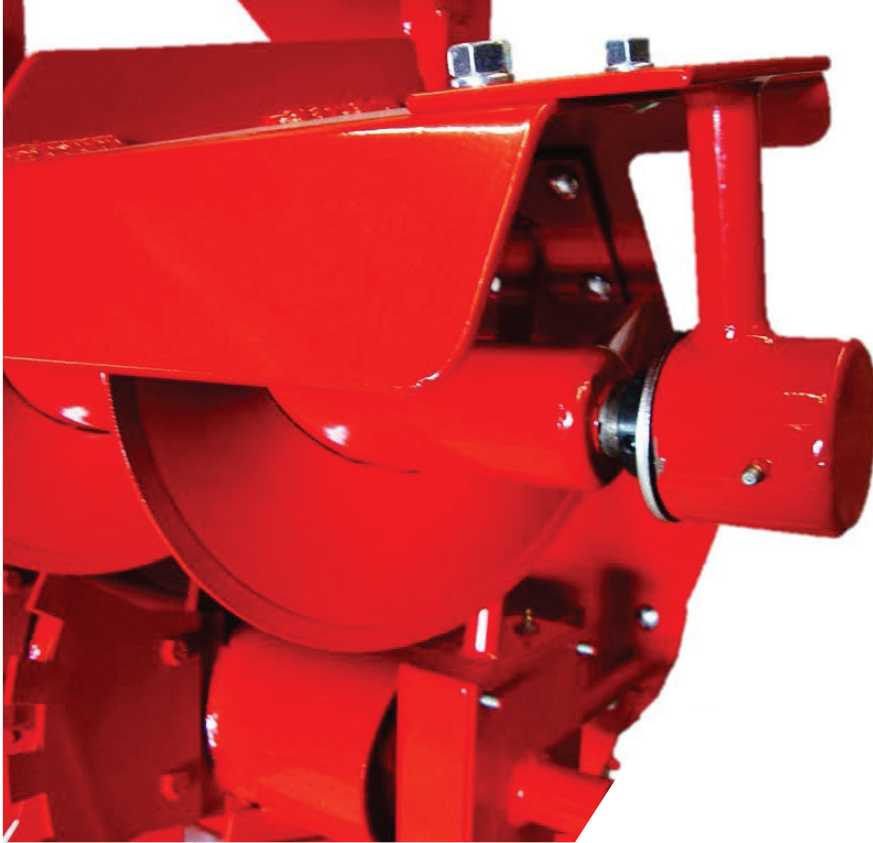
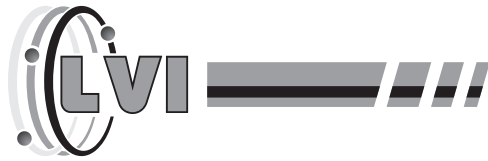

BALL BEARING UNIT

Outer end of top auger after SN 010114

- See next page

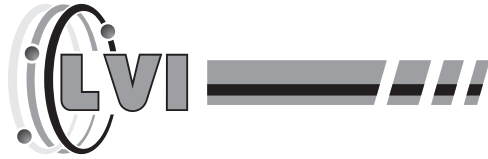

BALL BEARING UNIT

Collar washer #LT111514



Bearing with collar #LTB1316, 1 3/16" I.D.



Carrier frame #LT121614



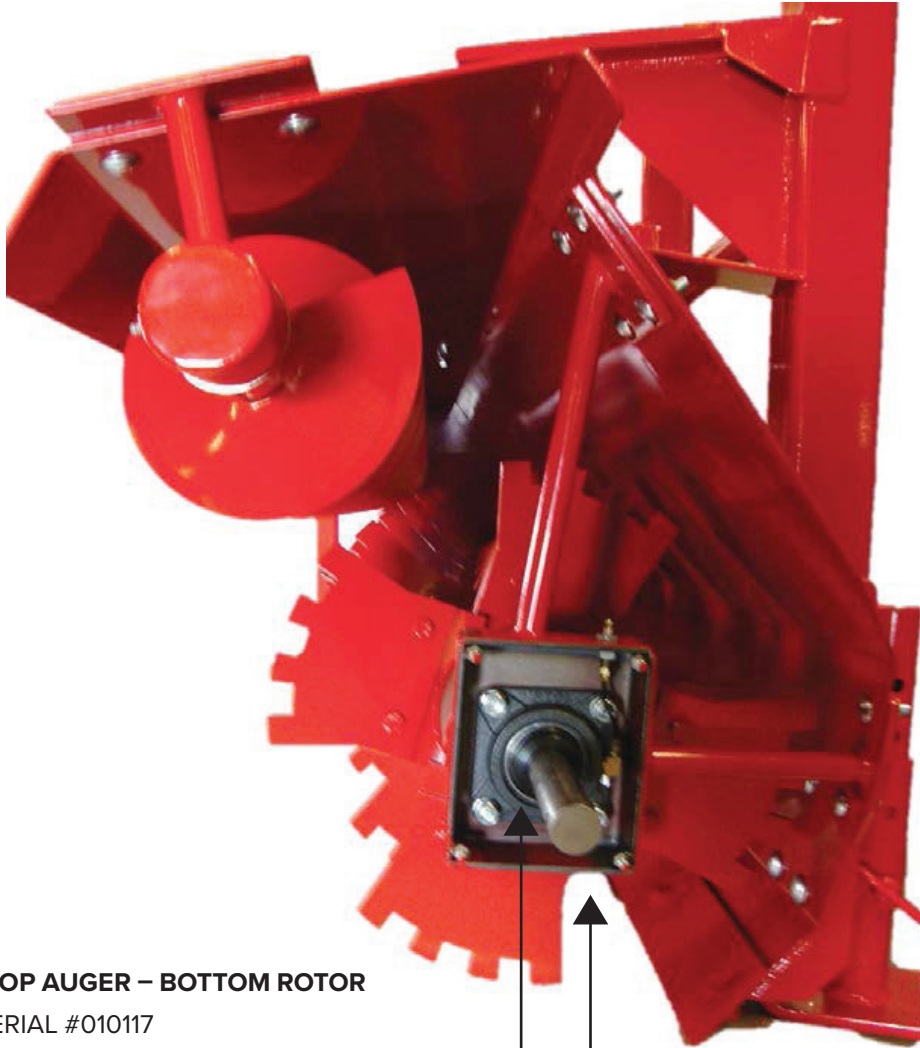
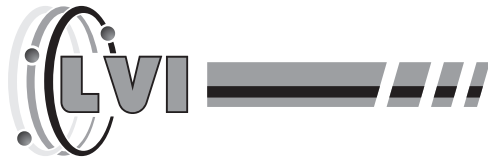

END VIEW TOP AUGER – BOTTOM ROTOR
PRIOR TO SERIAL #010117

#LTB1384

4 bolt 1 3/8" I.D. with collar lock

Square bracket #LT090115



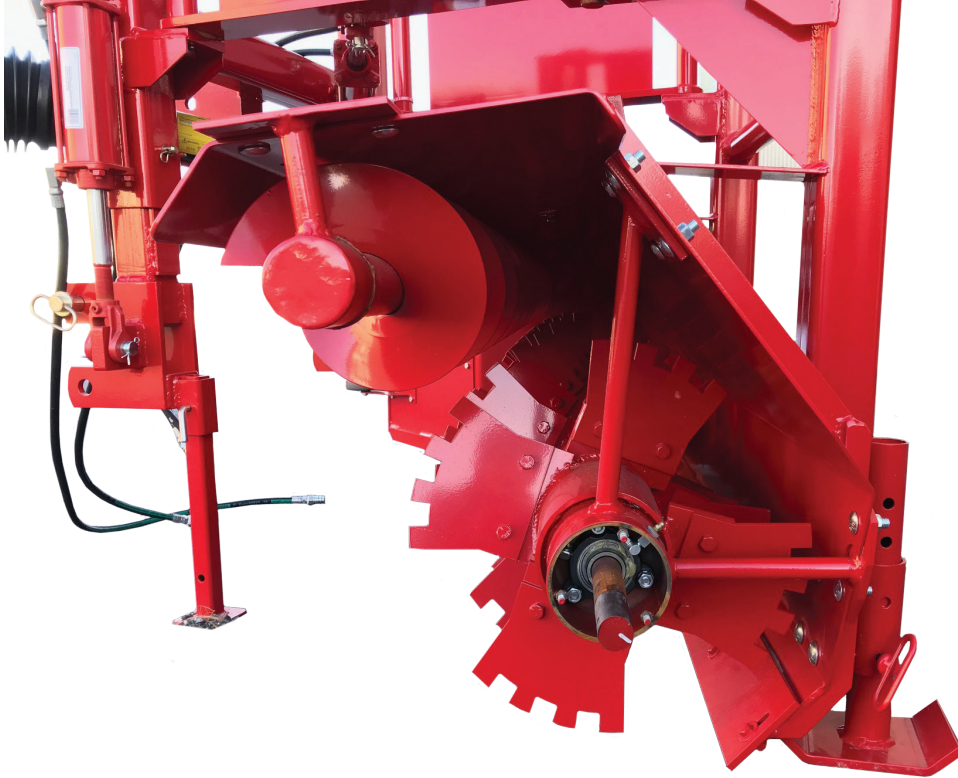
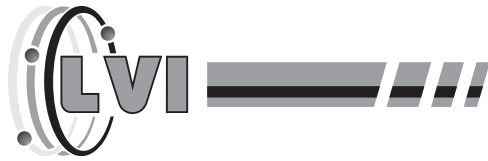

END VIEW TOP AUGER AND BOTTOM ROTOR

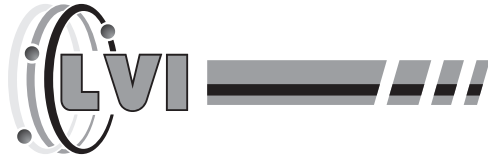

BEARING BOX

#LT090115
Bearing box frame (square),
with bearing & grease line installed without cover
Prior SN 112016

BEARING BOX COVER

#LT030515



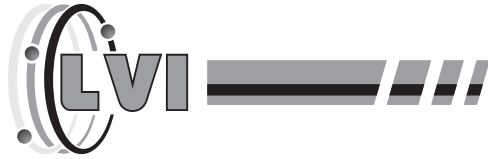

BEARING BOX

#LT081117

Bearing box frame (round), 3" wide
with bearing & grease line installed without cover

After serial #112016

Prior to serial #050820



BEARING BOX COVER

#LT210315



COVER LID GASKET

#LT030815, rubber



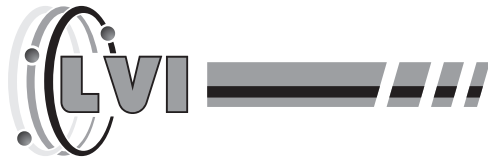

BEARING BOX FRAME

After serial #050820

4 1/2" wide

#LT200703, with bearing and greaseline installed.

Uses same: bearing, grease line components, cover, cover gasket as prior serial number unit.



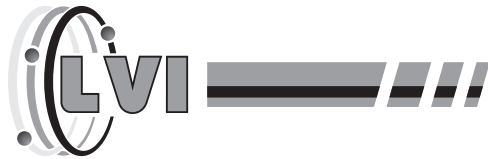

ROUND BEARING BOX

Bearing #LTB1383

1 3/8" I.D. set screw locking

3 bolt mount

(3) - 7/16 x 1 1/4" bolt

(3) - 7/16" nut

(3) - 7/16" lock washer

Grease tube items - see grease tube item page

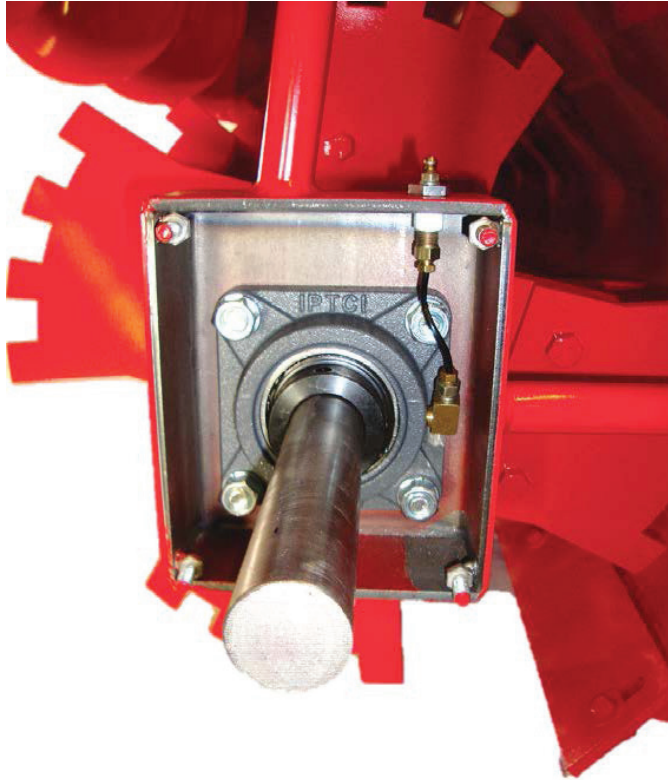
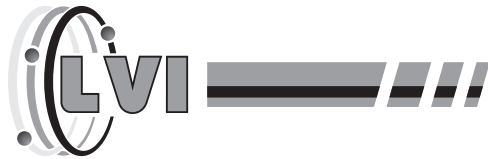

SQUARE ROTOR END BEARING BOX

#LTB1384 brg.

1 3/8" I.D. with lock collar

(4) 1/2" bolt holes

Retained with:

(4) - 1/2" x 1 1/2" bolt

(4) - 1/2" nut

(4) - 1/2" lock washer

Grease tube items - see grease tube item page

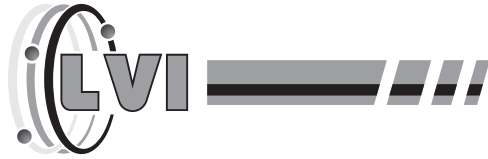

GREASE TUBE ASSEMBLY ITEMS

#LT1/4-28 zerks

#LT061848 nut

#LT061847 straight fitting

#LT061845 part fitting

#LT061846 part fitting

#LT700113359-6 plastic line

#LT061846 compression fitting

#LT061845 fitting

#LT216200 90° fitting 1/8" male NPT thread, check brg. thread size

#LT080861 90° fitting 1/4" male thread, check brg. thread size

- Round bearing box uses (2) 90° elbows (included in kit)

KIT PART

#LT012518 (includes all items)

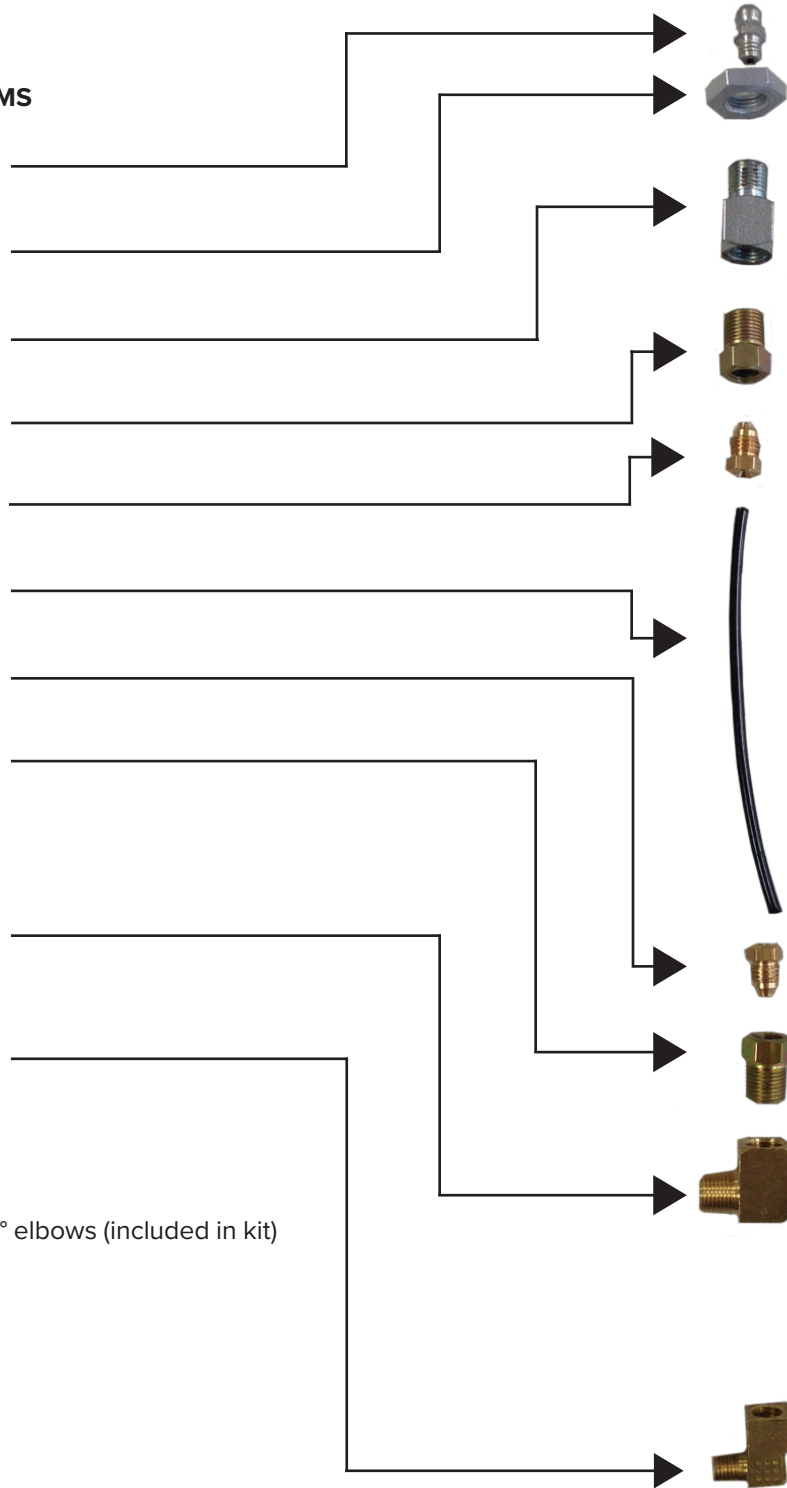

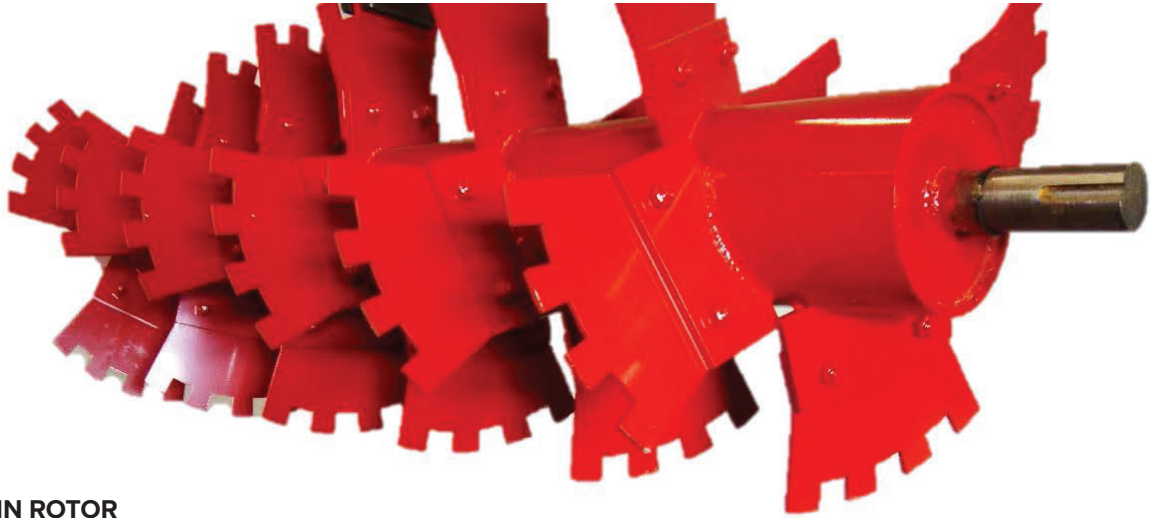
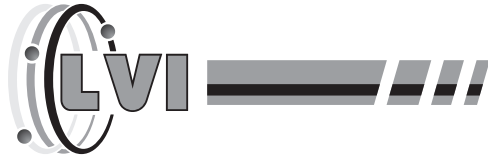

MAIN ROTOR

#LT082119, rotor unit with paddles installed

1 3/4" Snap Ring #LTSRE134

See next page for drive shaft of rotor

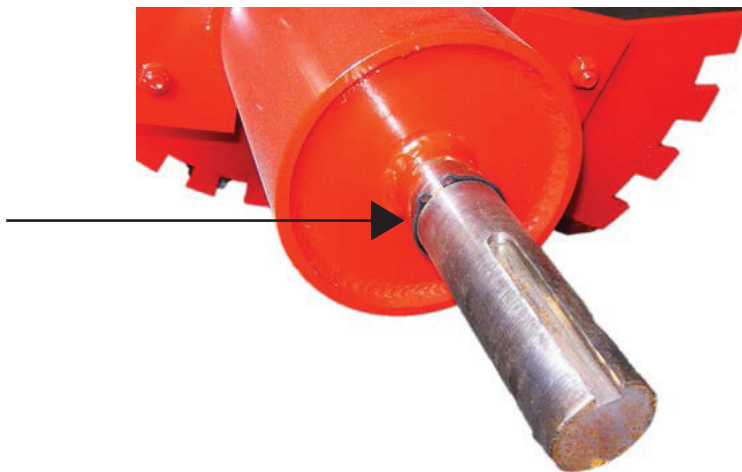

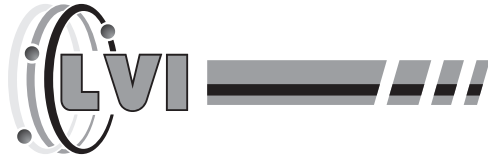

MAIN ROTOR DRIVE SHAFTS

DRIVE SHAFT

#LT111414, 1 3/4" x 24" long, hardened



#LT111714, 1 3/4" I.D.

2 discs needed when replacing this shaft



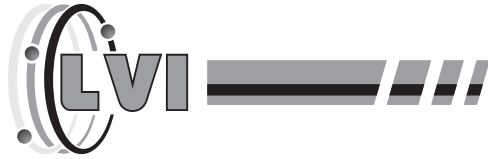

COMPLETE SHAFT WITH SHIELDS

Prior to serial #082727

Bare co #6 complete shaft with shields #LT69P522-40

6 spline quick disconnect - tractor end

1 3/8" round with 5/16 keyway - machine end with bolt clamp

3 lobe shaft tubes

Does not have CV joint at gear box end.

1 - 5/15 x 5/16 x 2" key, hardened #LT5165162

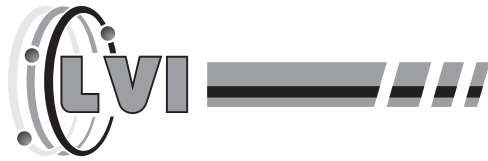

PTO SHAFT

Prior to #082717

Tractor yoke 6 spline disconnect
#MA622138

#MA6254 yoke

Cross kits: #MA600

Machine end yoke

#MA6245 yoke

1 3/8" round, 6/16 keyway with bolt clamp
MAE822335



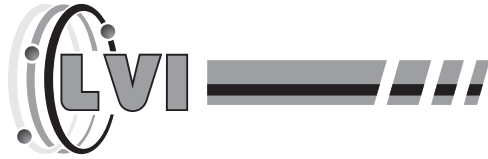

PTO SHAFT SHIELD

Prior to serial #082717

Shield / both halves, #MAS30130, will need to cut to proper length

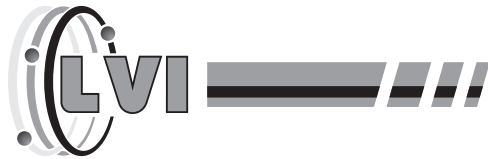

COMPLETE SHAFT ASSEMBLY

#LT79P5213BP, supercedes to LT79P5217BP

Used serial #082717 through #073018

Gear box end: CV joint with 1 3/8" round bore
with 5/16" key way
with 2 set screws

Tractor end: 6 spline quick disconnect

3 lobe shaft tubes

1 - 5/16 x 5/16 x 2" hardened key #LT5165162

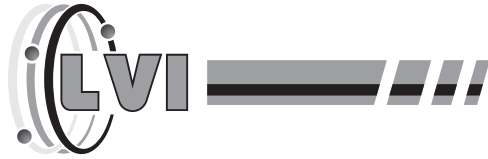

REAR 1/2 OF SHAFT

Cross kit #LTM4120G0051

“Bondiolo” CV assembly adapted to a 3” lobe tubing

1 3/8” round bore yoke with 5/16” key way

2 - set screws square head 3/8 x 3/4” long

2 - jam nut, 3/8”

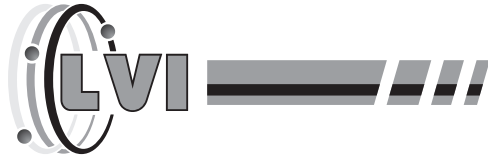

FRONT HALF OF PTO SHAFT #6 SERIES

#LT79P5113BP

6 spline quick disconnect

Cross kit #LTMA600

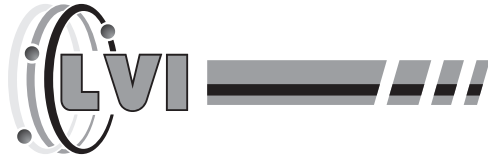

SHIELD ASSEMBLY - BOTH HALVES

Must cut to proper length #MAS30130

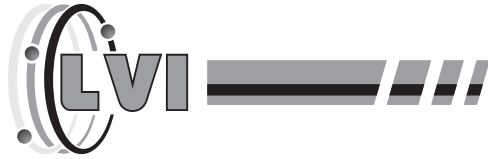

COMPLETE SHAFT ASSEMBLY

#LT79P5217BP

Used serial #073118 through #050920

Gear box end: 1 3/8" round bore

5/16" key way #LT5165162

2 set screws

CV joint

Tractor end 6 spline quick disconnect

4 lobe shaft tubings

"Bondioli" 43" overall length

Complete shield assembly #LT210316

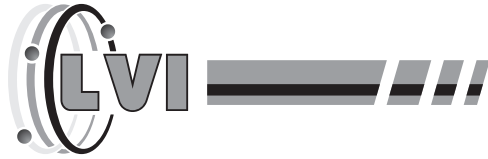

TRACTOR END OF SHAFT (4 LOBE OUTER PROFILE)

6 spline 1 3/8"

Quick disconnect

#6 series cross kit #LTMA600

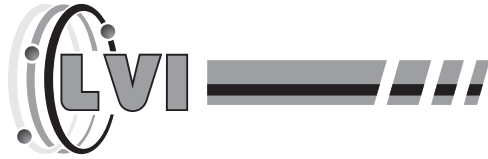

GEAR END OF SHAFT (4 LOBE OUTER PROFILE)

1 3/8" round

5/16" key way

Retained by:

(2) 3/8 x 3/4" square, hardened set screw

(2) 3/8" jam nut

1 - drive key 5/16 x 5/16 x 2", hardened #LT5165162

Cross kit #LT061114 (uses 2 kits)

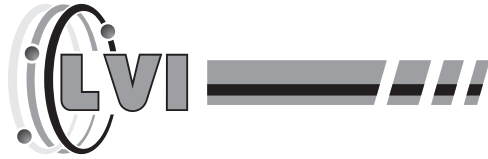

COMPLETE SHAFT ASSEMBLY

#LT79P5223BP

Used serial #051020 and later

Gear box: 6 spline

Retained by:

taper pin/bolt #LT408000075R (comes with new shaft assembly)

CV joint

Tractor end 6 spline quick disconnect

4 lobe shaft tubplings

“Bondiolo” 43” overall length

Shield assembly #LT210316

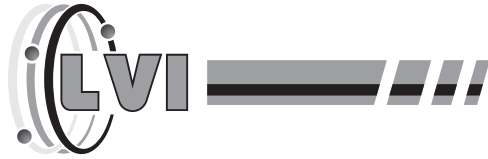

GEAR BOX END CV JOINT

Used serial #051020 and after
6 spline - Taper pin/bolt retained
(2) cross kit #LT061114
Retaining pin kit #LT408000075R

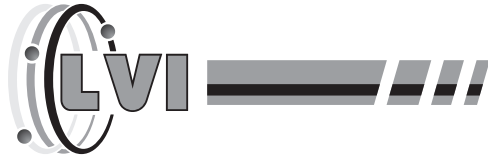

WARRANTY POLICY TERMS AND CONDITIONS

BINKLEY & HURST, LP P.O. BOX 100, 700 EAST LINDEN STREET, RICH LAND, PA 17087, provides the following limited warranty on its LVI-branded products in accordance with the provisions below to each original retail purchaser of new LVI equipment of its own manufacture. Such equipment is, at the time of delivery to end user, free from defects in material and workmanship and will be warranted for a period of **6 months for single farm use and 3 months for custom (for hire) use** from the date of delivery. The machine must be used and serviced in accordance with the recommendations of LVI and be operated under normal farm conditions for which the unit is designed.

1. This warranty will be void if any equipment is deemed by LVI to have been used for purposes other than that for which it is intended or if it has been misused, neglected, damaged, let out for hire or furnished for rental. Claims will not be accepted if parts other than those manufactured or supplied by LVI have been used on any LVI equipment. Further, LVI will not be responsible for damage incurred in transit or handling and under no circumstances within or without the warranty period will LVI be liable for damage claims due to downtime or inability to use the machine.
2. LVI will not be held responsible for loss of livestock, poultry, pets or any expense or costs incurred for labor, supplies, substitute machinery rental for any other reason, or for injuries either to the owner or to a third party. LVI is not responsible for labor charges, other than those originally agreed upon which are incidentally incurred in the removal or replacement of components on LVI product.
3. The Customer will be responsible for and bear the cost of:
 - a. Maintenance such as greasing, maintenance of oil levels, minor adjustments, timely replacement of wear items.
 - b. Transportation of any LVI product to and from where the warranty work is performed.
 - c. Dealer travel time to and from the machine or to deliver and return the machine from the workshop for repair.
 - d. Dealer travel costs.
4. Normal wearing items, (i.e. cutting edge, skid shoes, etc.) are not covered under this warranty.
5. This warranty will not apply to any product that is altered or modified without the express written permission of LVI. Warranty repairs must be authorized by LVI or LVI-approved dealers.

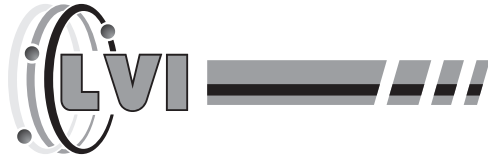

6. This warranty may not be assigned or transferred to anyone.
7. Signing this form indicates that i have read and understand the owners manual and am capable of operating the machine in a safe and responsible manner.

WARRANTY REGISTRATION

Customer Name: _____

Dealer Name: _____

Address: _____

City/State/Zip: _____

Phone: _____ Cell: _____

Machine Model: _____ Machine Serial: _____

Delivery Date: _____ Sales Person: _____

Customer Signature: _____

3 COPIES REQUIRED: 1-BINKLEY & HURST, LP 2-DEALER 3-CUSTOMER

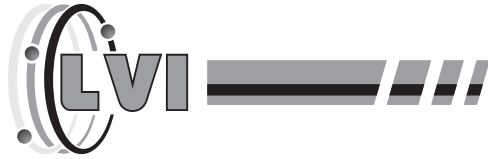

WARRANTY POLICY TERMS AND CONDITIONS

BINKLEY & HURST, LP P.O. BOX 100, 700 EAST LINDEN STREET, RICH LAND, PA 17087, provides the following limited warranty on its LVI-branded products in accordance with the provisions below to each original retail purchaser of new LVI equipment of its own manufacture. Such equipment is, at the time of delivery to end user, free from defects in material and workmanship and will be warranted for a period of **6 months for single farm use and 3 months for custom (for hire) use** from the date of delivery. The machine must be used and serviced in accordance with the recommendations of LVI and be operated under normal farm conditions for which the unit is designed.

1. This warranty will be void if any equipment is deemed by LVI to have been used for purposes other than that for which it is intended or if it has been misused, neglected, damaged, let out for hire or furnished for rental. Claims will not be accepted if parts other than those manufactured or supplied by LVI have been used on any LVI equipment. Further, LVI will not be responsible for damage incurred in transit or handling and under no circumstances within or without the warranty period will LVI be liable for damage claims due to downtime or inability to use the machine.
2. LVI will not be held responsible for loss of livestock, poultry, pets or any expense or costs incurred for labor, supplies, substitute machinery rental for any other reason, or for injuries either to the owner or to a third party. LVI is not responsible for labor charges, other than those originally agreed upon which are incidentally incurred in the removal or replacement of components on LVI product.
3. The Customer will be responsible for and bear the cost of:
 - a. Maintenance such as greasing, maintenance of oil levels, minor adjustments, timely replacement of wear items.
 - b. Transportation of any LVI product to and from where the warranty work is performed.
 - c. Dealer travel time to and from the machine or to deliver and return the machine from the workshop for repair.
 - d. Dealer travel costs.
4. Normal wearing items, (i.e. cutting edge, skid shoes, etc.) are not covered under this warranty.
5. This warranty will not apply to any product that is altered or modified without the express written permission of LVI. Warranty repairs must be authorized by LVI or LVI-approved dealers.

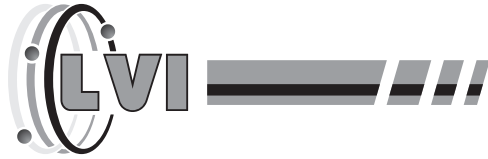

6. This warranty may not be assigned or transferred to anyone.
7. Signing this form indicates that i have read and understand the owners manual and am capable of operating the machine in a safe and responsible manner.

WARRANTY REGISTRATION

Customer Name: _____

Dealer Name: _____

Address: _____

City/State/Zip: _____

Phone: _____ Cell: _____

Machine Model: _____ Machine Serial: _____

Delivery Date: _____ Sales Person: _____

Customer Signature: _____

3 COPIES REQUIRED: 1-BINKLEY & HURST, LP 2-DEALER 3-CUSTOMER

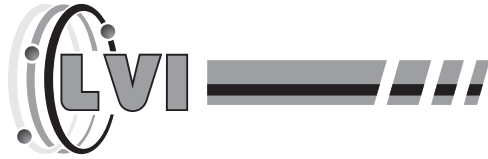

WARRANTY POLICY TERMS AND CONDITIONS

BINKLEY & HURST, LP P.O. BOX 100, 700 EAST LINDEN STREET, RICH LAND, PA 17087, provides the following limited warranty on its LVI-branded products in accordance with the provisions below to each original retail purchaser of new LVI equipment of its own manufacture. Such equipment is, at the time of delivery to end user, free from defects in material and workmanship and will be warranted for a period of **6 months for single farm use and 3 months for custom (for hire) use** from the date of delivery. The machine must be used and serviced in accordance with the recommendations of LVI and be operated under normal farm conditions for which the unit is designed.

1. This warranty will be void if any equipment is deemed by LVI to have been used for purposes other than that for which it is intended or if it has been misused, neglected, damaged, let out for hire or furnished for rental. Claims will not be accepted if parts other than those manufactured or supplied by LVI have been used on any LVI equipment. Further, LVI will not be responsible for damage incurred in transit or handling and under no circumstances within or without the warranty period will LVI be liable for damage claims due to downtime or inability to use the machine.
2. LVI will not be held responsible for loss of livestock, poultry, pets or any expense or costs incurred for labor, supplies, substitute machinery rental for any other reason, or for injuries either to the owner or to a third party. LVI is not responsible for labor charges, other than those originally agreed upon which are incidentally incurred in the removal or replacement of components on LVI product.
3. The Customer will be responsible for and bear the cost of:
 - a. Maintenance such as greasing, maintenance of oil levels, minor adjustments, timely replacement of wear items.
 - b. Transportation of any LVI product to and from where the warranty work is performed.
 - c. Dealer travel time to and from the machine or to deliver and return the machine from the workshop for repair.
 - d. Dealer travel costs.
4. Normal wearing items, (i.e. cutting edge, skid shoes, etc.) are not covered under this warranty.
5. This warranty will not apply to any product that is altered or modified without the express written permission of LVI. Warranty repairs must be authorized by LVI or LVI-approved dealers.

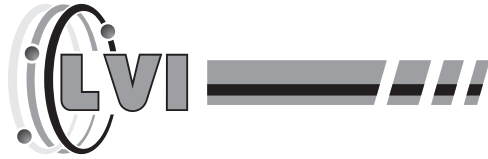

6. This warranty may not be assigned or transferred to anyone.
7. Signing this form indicates that i have read and understand the owners manual and am capable of operating the machine in a safe and responsible manner.

WARRANTY REGISTRATION

Customer Name: _____

Dealer Name: _____

Address: _____

City/State/Zip: _____

Phone: _____ Cell: _____

Machine Model: _____ Machine Serial: _____

Delivery Date: _____ Sales Person: _____

Customer Signature: _____

3 COPIES REQUIRED: 1-BINKLEY & HURST, LP 2-DEALER 3-CUSTOMER